



Ersatzteilliste
Spare Parts List
Liste des pièces de rechange

HDS 600 C

1.962-131.0 HDS 600 C + RM TANK

GRUPPE: 1.0 EINZELTEILE
GROUP: 1.0 PIECE PARTS
GRUPPE: 1.0 PIECES CONSTITUANTES

A1

HDS 600 C

GRUPPE: 1.0 EINZELTEILE
GROUP: 1.0 PIECE PARTS
GRUPPE: 1.0 PIECES CONSTITUANTES

Ersatzteile unter www.gluesing.net

GRUPPE: 1.0 EINZELTEILE
GROUP: 1.0 PIECE PARTS
GRUPPE: 1.0 PIÈCES CONSTITUANTES

B1

HDS 600 C

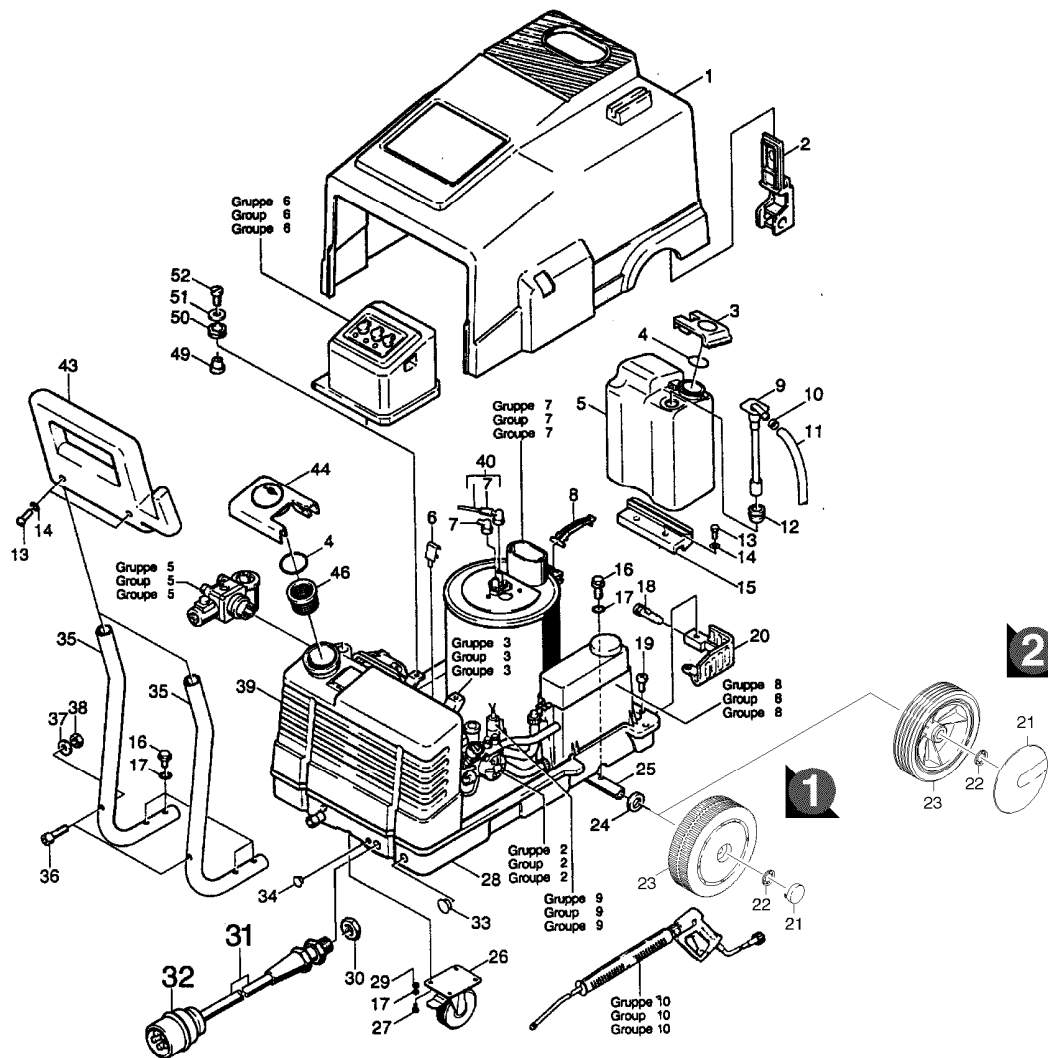

Symbolbeschreibung siehe M16 / symbol description see M16 / désignation de système voir M16 /

GRUPPE: 1.0 EINZELTEILE
 GROUP: 1.0 PIECE PARTS
 GROUPE: 1.0 PIECES CONSTITUANTES

C1

HDS 600 C

POS. ITM. POS.	BENNENNUNG DESCRIPTION DESIGNATION	TEILE-NR. PART-NO. NO.PIECE	STCK QTY. NBR.	POS. ITM. POS.	BENNENNUNG DESCRIPTION DESIGNATION	TEILE-NR. PART-NO. NO.PIECE	STCK QTY. NBR.
1	HAUBE / COVER / CAPOT	5.066-686.0	1	27	6KT-SCHR. M 8X 16 / HEXAGONAL HEAD SCREW / VIS HEXAGONAL	7.304-395.0	4
2	HALTER / BRACKET / FIXATION	5.042-462.0	2	28	RAHMEN / FRAME / CADRE	5.050-032.0	1
3	DECKEL / COVER / COUVERCLE	5.063-360.0	1	29	6KT-MUTTER M 8 / HEXAGON NUT / ECROU HEXAGONAL	7.311-004.0	4
4	O-RING 50,0 X 4,0 / GASKET / BAQUE D'ETANCHEITE	6.362-635.0	2	30	GEGENMUTTER PG13.5 / COUNTERNUT / CONTRE-ECROU	6.641-480.0	1
5	CHEMIETANK / CHEMISTRIE TANK / RESERVOIR A CHEMIE	5.071-038.0	1	31	KABEL / CABLE / CABLE	4.820-161.0	1
6	HALTER / BRACKET / FIXATION	5.042-464.0	2	32	CEE-STECKER 16A / CEE-PLUG / CEE-FICHE	6.646-030.0	1
7	KERZENSTECKER / SPARK PLUG SOCKET / COSSE DE BOUGIE	6.618-057.0	2	33	ABDECKKAPPE / CAP / CHAPE	6.368-127.0	1
8	HALTER / BRACKET / FIXATION	5.042-463.0	1	35	GRIFF / HANDLE / POIGNEE	5.321-239.0	2
9	FILTER / FILTER / FILTRE	6.414-028.0	1	36	ZYL.SCHR. M 6X 45 / CHEESE HEAD SCREW / VIS A TETE CYLINDR.	7.306-514.0	2
10	SCHLAUCHSCHELLE / HOSE BAND CLIP / COLLIER DE SERRAGE	6.388-559.0	2	37	SCHEIBE 6 / WASHER / RONDELLE	7.312-260.0	2
11	SCHLAUCH DN 7 / HOSE / TUYAU FLEXIBLE	6.388-225.0	3	38	6KT-MUTTER M 6 / HEXAGON NUT / ECROU HEXAGONAL	7.311-512.0	2
12	PROFILDICHTUNG / SEAL / ETOUPE PROFILE	5.365-147.0	1	39	TANK / TANK / RESERVOIR	5.071-037.0	1
13	SCHRAUBE M 6X 20 / SCREW / VIS	6.303-105.0	2	40	ZUENDKABEL / IGNITION CABLE / FIL D'AMORCE	4.821-020.0	2
14	SCHEIBE 6 / WASHER / RONDELLE	7.312-291.0	2	43	GRIFF / HANDLE / POIGNEE	5.321-238.0	1
15	AUFLAGER / SUPPORT / SUPPORT	5.057-040.0	1	44	DECKEL / COVER / COUVERCLE	5.063-326.0	1
16	SCHRAUBE M 8X 16 / SCREW / VIS	6.303-031.0	6	46	SIEB / STRAINER / CREPINE	6.414-340.0	1
17	ZAHNSCHEIBE A 8,4 / LOCK WASHER / ROUE PLATE	7.312-166.0	10	49	HUELSE / SLEEVE / DOUILLE	5.110-357.0	4
18	BOLZEN / BOLT / BOULON	5.316-240.0	2	50	GUMMIRING / RUBBER RING / RONDELLE CAOUTCHOUC	5.379-013.0	4
19	BL.SCHR. ST4,8X19 / SHEET METAL SCREW / VIS A TOLE	7.303-078.0	4	51	SCHEIBE 5 / WASHER / RONDELLE	7.312-264.0	4
20	GRIFF RECHTS / HANDLE / POIGNEE	5.321-278.0	1	52	SCHNEIDSCHR. M5X 25 / SELF-TAPPING SCREW / VIS AUTOTARAUDEUSE	6.303-086.0	4
20	GRIFF LINKS / HANDLE / POIGNEE	5.321-280.0	1				
21	KAPPE / CAP / CAPUCHON	5.392-013.0	2				
	VERSION 1/VERSION 1/VERSION 1						
21	RADKAPPE / WHEEL CAB / ENJOLIVEUR	6.435-237.0	2				
	VERSION 2/VERSION 2/VERSION 2						
22	SICHERUNGSSCHEIBE / LOCK WASHER / RONDELLE D'ARRET	6.343-162.0	2				
23	RAD / WHEEL / ROUE	5.515-011.0	2				
	VERSION 1/VERSION 1/VERSION 1						
23	RAD D.250 / WHEEL / ROUE	6.435-236.0	2				
	VERSION 2/VERSION 2/VERSION 2						
24	HUELSE / SLEEVE / DOUILLE	5.110-358.0	2				
	VERSION 1/VERSION 1/VERSION 1						
24	HUELSE / SLEEVE / DOUILLE	5.110-561.0	2				
	VERSION 2/VERSION 2/VERSION 2						
25	ACHSE / AXLE / ESSIEU	5.105-086.0	1				
26	LENKROLLE / CASTOR / ROUE PIVOTANTE	6.435-116.0	1				

"=> xxxxxx" = bis Werknummer / up to serial No. / jusqu' au No. de fabr. / "xxxxxx =>" = ab Werknummer / from serial No. / a partir du No. de fabr. /

GRUPPE: 2.0 PUMPENSATZ
GROUP: 2.0 PUMP SET
GRUPPE: 2.0 JEU (ENSEMBLE) DE POMPE

A2

HDS 600 C

GRUPPE: 2.0 PUMPENSATZ
GROUP: 2.0 PUMP SET
GRUPPE: 2.0 JEU (ENSEMBLE) DE POMPE

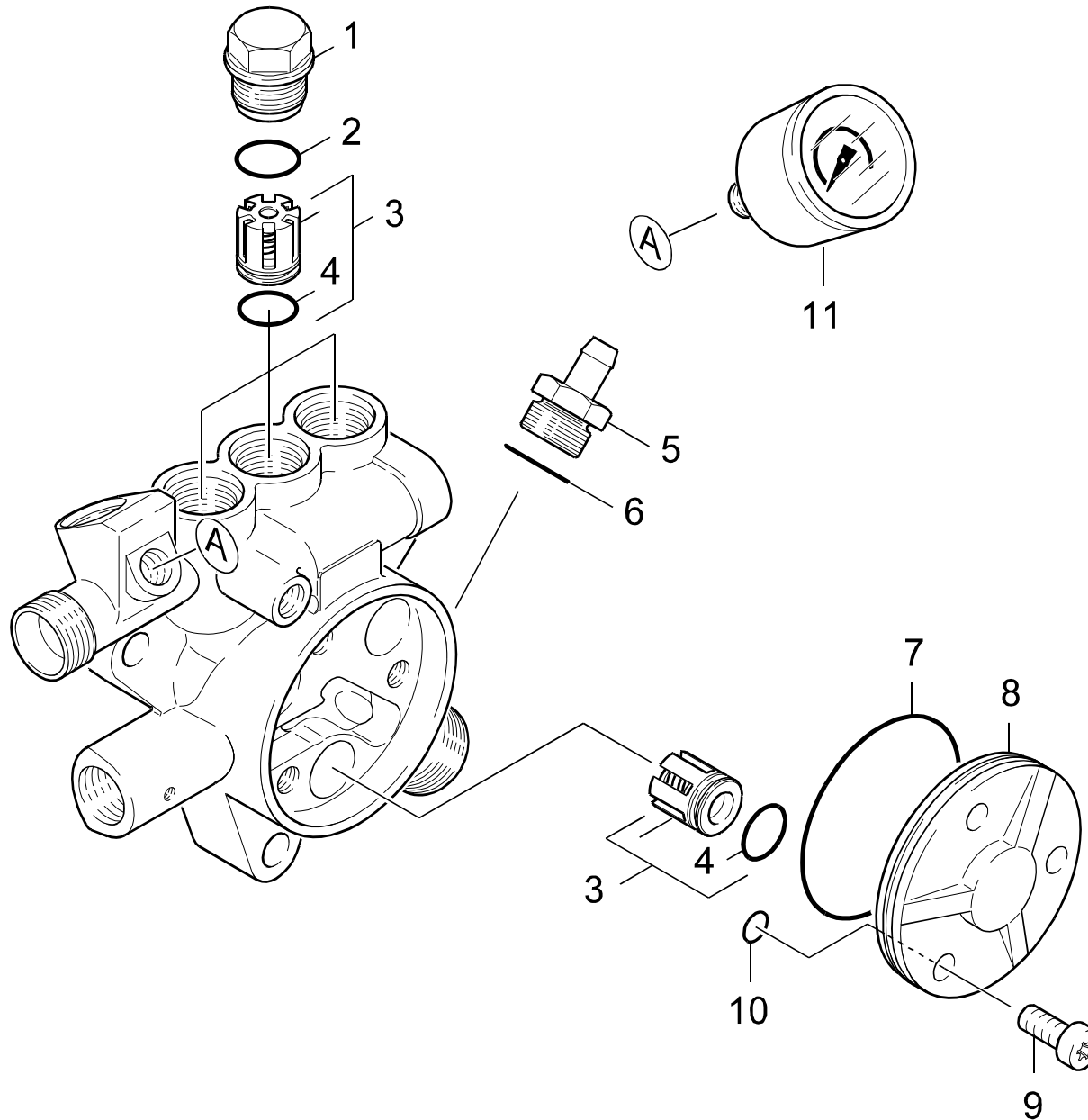

Symbolbeschreibung siehe M16 / symbol description see M16 / désignation de système voir M16 /

GRUPPE: 2.1 VENTILE
GROUP: 2.1 VALVES
GROUPE: 2.1 SOUPAPES

C2

HDS 600 C

POS. ITM. POS.	BENNENUNG DESCRIPTION DESIGNATION	TEILE-NR. PART-NO. NO.PIECE	STCK QTY. NBR.
1	VENTILSCHRAUBE / VALVE SCREW / VIS POINTEAU (SOUP.)	5.583-115.0	3
2	O-RING 17,3 X 2,4 / GASKET / BAQUE D'ETANCHEITE	6.362-160.0	3
3	VENTIL KPL. / VALVE / SOUPAPE	4.580-329.0	6
4	O-RING 13,0 X 2,0 / GASKET / BAQUE D'ETANCHEITE	6.362-381.0	6
5	VENTIL / VALVE / SOUPAPE	4.580-114.0	1
6	O-RING 15,0 X 2,0 / GASKET / BAQUE D'ETANCHEITE	6.362-427.0	1
7	O-RING 60,0 X 2,0 / GASKET / BAQUE D'ETANCHEITE	6.362-204.0	1
8	DECKEL / COVER / COUVERCLE	5.063-354.0	1
9	ZYL.SCHR. M 8X 20 / CHEESE HEAD SCREW / VIS A TETE CYLINDR.	6.304-038.0	3
10	O-RING 9,0 X 1,5 / GASKET / BAQUE D'ETANCHEITE	6.362-384.0	3
11	MANOMETER 0-300 BAR / PRESSURE GAUGE / MANOMETRE	6.421-214.0	1
100	PUMPENSET / PUMP SET / GROUPE DE POMPES	2.883-172.0	1

"=> xxxxxx" = bis Werknummer / up to serial No. / jusqu' au No. de fabr. / "xxxxxx =>" = ab Werknummer / from serial No. / a partir du No. de fabr. /

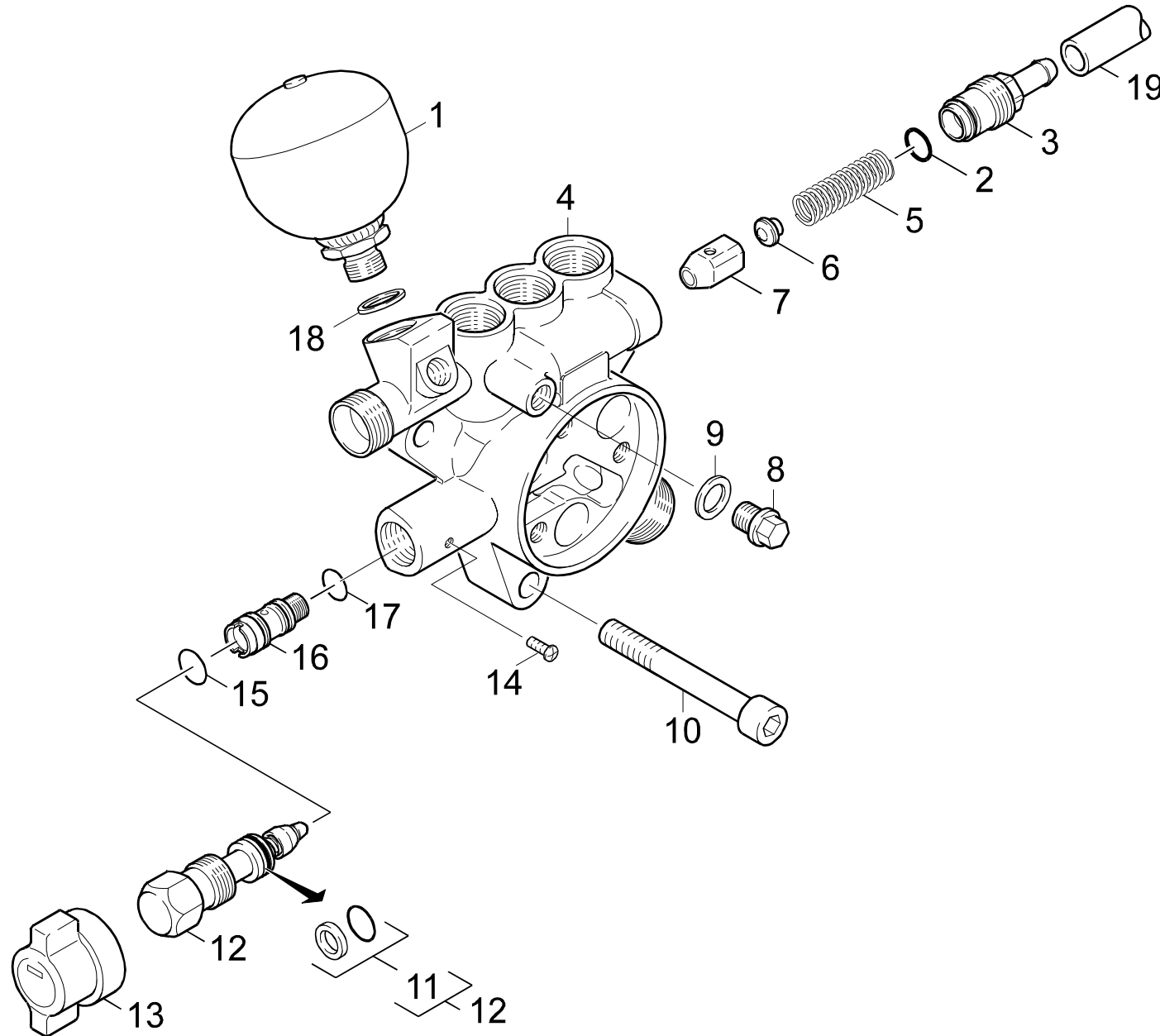

Symbolbeschreibung siehe M16 / symbol description see M16 / désignation de système voir M16 /

GRUPPE: 2.2 PUMPENSATZ
 GROUP: 2.2 PUMP SET
 GROUPE: 2.2 JEU (ENSEMBLE) DE POMPE

E2

HDS 600 C

POS. ITM. POS.	BENNENUNG DESCRIPTION DESIGNATION	TEILE-NR. PART-NO. NO.PIECE	STCK QTY. NBR.
1	DRUCKSPEICHER / PULSATION DAMPER / ANTI-BELIER	6.505-025.0	1
2	O-RING 12,0 X 2,0 / GASKET / BAQUE D'ETANCHEITE	6.362-169.0	1
3	VENTILSCHRAUBE / VALVE SCREW / VIS POINTEAU (SOUP.)	5.583-106.0	1
4	ZYLINDERKOPF KPL. / CYLINDER HEAD / CULASSE	4.550-114.0	1
5	SCHRAUBENFEDER / HELICAL SPRING / RESSORT CYLINDRIQUE	5.332-140.0	1
6	VENTILBOLZEN / VALVE PIN / BOULON DE SOUPAPE	5.584-060.0	1
7	VENTILTeller KPL / VALVE DISC / TETE DE SOUPAPE	4.582-007.0	1
8	DICHTRING 10 X13,5 / JOINT RING / BAGUE D'ETANCHEITE	7.362-003.0	1
9	VS-SCHRAUBE M10X1,0 / CLOSING SCREW / VIS DE FERMETURE	7.382-085.0	1
10	ZYL.SCHR. M10X 70 / CHEESE HEAD SCREW / VIS A TETE CYLINDR.	7.306-125.0	3
11	O-RING 12,42 KOMPL / GASKET / BAQUE D'ETANCHEITE	6.362-575.0	1
12	SPINDEL / SPINDLE / PIVOT	4.291-009.0	1
13	GRIFF / HANDLE / POIGNEE	5.321-263.0	1
14	LINSENSCHR. M 4X 6 / OVAL HEAD SCREW / VIS A TETE BOMBEE	7.306-323.0	1
15	O-RING 11,0 X 1,3 / GASKET / BAQUE D'ETANCHEITE	6.362-402.0	1
16	HUELSE / SLEEVE / DOUILLE	5.110-384.0	1
17	O-RING 10 X 1,5 / GASKET / BAQUE D'ETANCHEITE	6.362-482.0	1
18	DICHTRING 14 X18 / JOINT RING / BAGUE D'ETANCHEITE	7.362-005.0	1
19	SCHLAUCH DN15 / HOSE / TUYAU FLEXIBLE	6.388-167.0	1
100	PUMPENSET / PUMP SET / GROUPE DE POMPES	2.883-172.0	1

"=> xxxxxx" = bis Werknummer / up to serial No. / jusqu' au No. de fabr. / "xxxxxx =>" = ab Werknummer / from serial No. / a partir du No. de fabr. /

GRUPPE: 2.3 KOLBEN
GROUP: 2.3 PISTON
GROUPE: 2.3 PISTON

G2

HDS 600 C

POS. ITM. POS.	BENNENUNG DESCRIPTION DESIGNATION	TEILE-NR. PART-NO. NO.PIECE	STCK QTY. NBR.
1	KOLBEN KPL. / PISTON / PISTON	4.553-124.0	3
2	GEHAEUSE / HOUSING / BOITIER	5.060-326.0	1
3	O-RING 101,27X 2,62 / GASKET / BAQUE D'ETANCHEITE	6.362-613.0	1
4	FORMTEIL / MOULDED PART / PREFORME	5.030-602.0	3
5	SCHRAUBENFEDER / HELICAL SPRING / RESSORT CYLINDRIQUE	5.332-139.0	3
6	ZYL.SCHR. M 6X 25 / CHEESE HEAD SCREW / VIS A TETE CYLINDR.	7.306-023.0	2
7	NUTRING 18X26X6/8 / GROOVED RING / JOINT A LEVRES	6.365-334.0	3
8	SCHEIBE / WASHER / RONDELLE	5.115-432.0	3
9	KOMPAKTDI. .18X28X6 / SEAL / JOINT	6.365-332.0	3
10	BUCHSE / BUSH / DOUILLE	5.112-340.0	3
11	O-RING 33,05X 1,78 / GASKET / BAQUE D'ETANCHEITE	6.362-406.0	3
12	SCHEIBE / WASHER / RONDELLE	5.115-431.0	3
13	NUTRING 18X26X5,4 / GROOVED RING / JOINT A LEVRES	6.365-333.0	3
14	SPRENGRING A 18 / RETAINER / CIRCLIP	7.343-473.0	3
15	GETRIEBEOEL 1L / GEAR LUBRICANT OIL / HUILE A ENGRENAGES	6.288-016.0	1
100	PUMPENSET / PUMP SET / GROUPE DE POMPES	2.883-172.0	1

"=> xxxxxx" = bis Werknummer / up to serial No. / jusqu' au No. de fabr. / "xxxxxx =>" = ab Werknummer / from serial No. / a partir du No. de fabr. /

GRUPPE: 3.0 MOTOR
GROUP: 3.0 MOTOR
GRUPPE: 3.0 MOTEUR

A3

HDS 600 C

GRUPPE: 3.0 MOTOR
GROUP: 3.0 MOTOR
GRUPPE: 3.0 MOTEUR

GRUPPE: 3.0 MOTOR
GROUP: 3.0 MOTOR
GRUPPE: 3.0 MOTEUR

B3

HDS 600 C

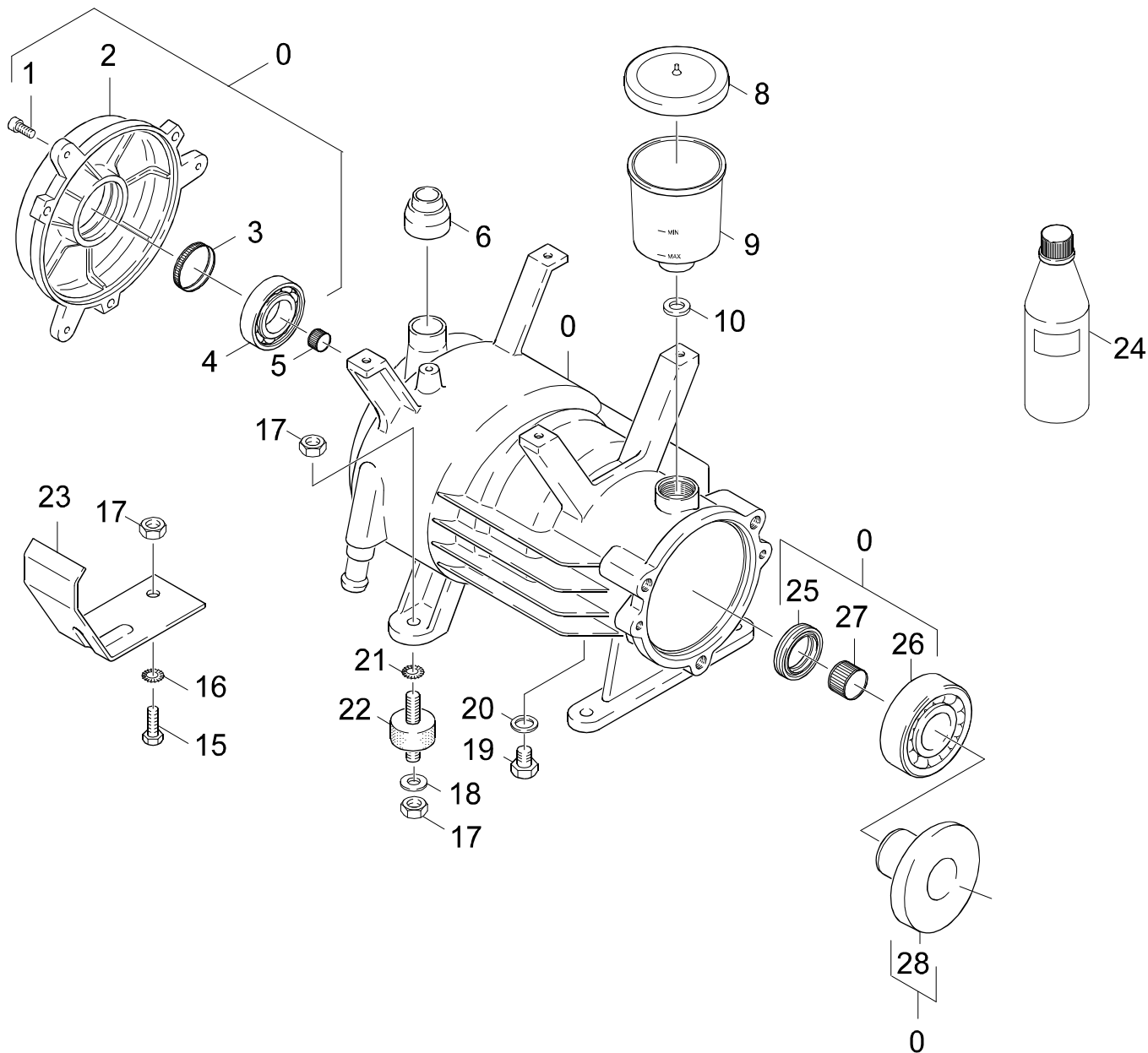

Symbolbeschreibung siehe M16 / symbol description see M16 / désignation de système voir M16 /

GRUPPE: 3.0 MOTOR
GROUP: 3.0 MOTOR
GROUPE: 3.0 MOTEUR

C3

HDS 600 C

POS. ITM. POS.	BENNENUNG DESCRIPTION DESIGNATION	TEILE-NR. PART-NO. NO.PIECE	STCK QTY. NBR.
0	MOTOR KPL. / MOTOR / MOTEUR	4.623-213.0	1
1	ZYL.SCHR. M 6X 20 / CHEESE HEAD SCREW / VIS A TETE CYLINDR.	7.306-022.0	3
2	DECKEL / COVER / COUVERCLE	5.063-349.0	1
3	TOLERANZRING 47X8 / TOLERANCE RING / BAGUE	6.343-029.0	1
4	KUGELLAGER 6204-2Z / BALL BEARING / ROULEMENT A BILLE	7.401-126.0	1
5	TOLERANZRING D14X8 / TOLERANCE RING / BAGUE	6.343-166.0	1
6	PROFILDICHTUNG / SEAL / ETOUPE PROFILE	5.365-148.0	1
8	DECKEL / COVER / COUVERCLE	5.063-189.0	1
9	BEHAELTER / TANK / BAC	5.070-048.0	1
10	DICHTRING / JOINT RING / BAGUE D'ETANCHEITE	5.363-100.0	1
15	6KT-SCHR. M 8X 16 / HEXAGONAL HEAD SCREW / VIS HEXAGONAL	7.304-395.0	2
16	ZAHNSCHEIBE A 8,4 / LOCK WASHER / ROUE PLATE	7.312-166.0	2
17	6KT-MUTTER M 8 / HEXAGON NUT / ECROU HEXAGONAL	7.311-004.0	10
18	FEDERRING B 8 / SPRING WASHER / RONDELLE GROWER	7.313-004.0	4
19	VS-SCHRAUBE M12X1,5 / CLOSING SCREW / VIS DE FERMETURE	7.382-232.0	1
20	DICHTRING 12 X15,5 / JOINT RING / BAGUE D'ETANCHEITE	7.362-004.0	1
21	ZAHNSCHEIBE A 10,5 / LOCK WASHER / ROUE PLATE	7.312-160.0	4
22	GUMMIPUFFER / RUBBER BUFFER / BUTOIR CAOUTCHOUC	6.339-095.0	4
23	WINKEL / ANGLE / ANGLE	5.018-621.0	1
24	GETRIEBEOEL 1L / GEAR LUBRICANT OIL / HUILE A ENGRENAGES	6.288-016.0	1
25	RWDR A28 X 47 X 7 / ROTARY SHAFT SEAL / JOINT (ARBRE)	7.367-017.0	1
26	KUGELLAGER 7307B-TN / BALL BEARING / ROULEMENT A BILLE	7.401-035.0	1
27	TOLERANZRING / TOLERANCE RING / BAGUE	6.343-024.0	1
28	TAUMELSCHIEBE / SWASH PLATE / DISQUE EN NUTATION	5.120-246.0	1

"=> xxxxxx" = bis Werknummer / up to serial No. / jusqu' au No. de fabr. / "xxxxxx =>" = ab Werknummer / from serial No. / a partir du No. de fabr. /

GRUPPE: 4.0 GEBLAESE
GROUP: 4.0 BLOWER
GRUPPE: 4.0 VENTILATEUR

A4

HDS 600 C

GRUPPE: 4.0 GEBLAESE
GROUP: 4.0 BLOWER
GRUPPE: 4.0 VENTILATEUR

Ersatzteile unter www.gluesing.net

GRUPPE: 4.0 GEBLAESE
GROUP: 4.0 BLOWER
GRUPPE: 4.0 VENTILATEUR

B4

HDS 600 C

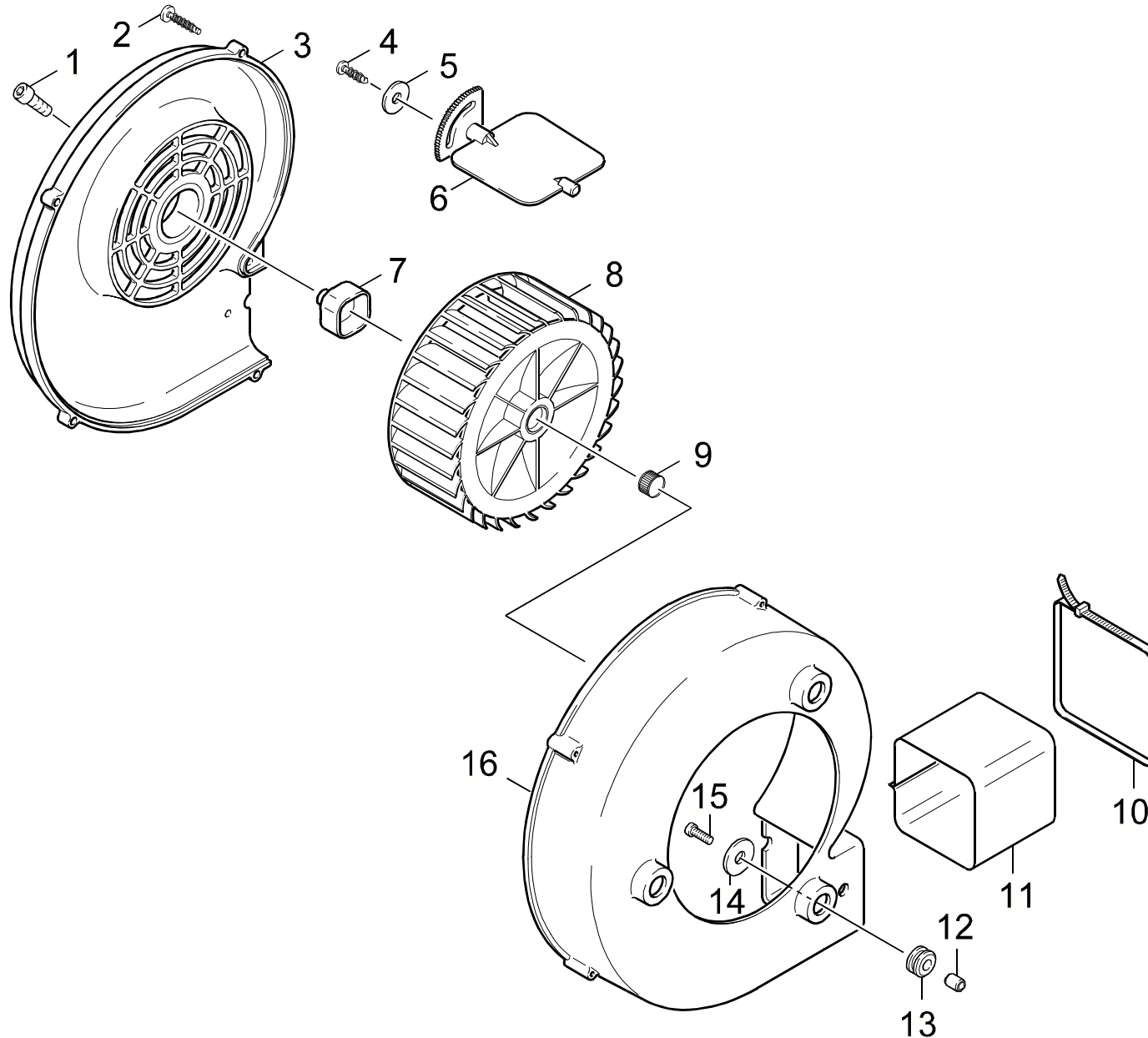

Symbolbeschreibung siehe M16 / symbol description see M16 / désignation de système voir M16 /

GRUPPE: 4.0 GEBLAESE
GROUP: 4.0 BLOWER
GROUPE: 4.0 VENTILATEUR

C4

HDS 600 C

POS. ITM. POS.	BENNENUNG DESCRIPTION DESIGNATION	TEILE-NR. PART-NO. NO.PIECE	STCK QTY. NBR.
1	SCHRAUBE M 6X 16 / SCREW / VIS	7.306-090.0	1
2	LINSENSCHR. 4,0X25 / OVAL HEAD SCREW / VIS A TETE BOMBEE	6.303-089.0	5
3	DECKEL / COVER / COUVERCLE	5.063-274.0	1
4	BL.SCHR. ST4,8X16 / SHEET METAL SCREW / VIS A TOLE	7.303-077.0	1
5	SCHEIBE 5 / WASHER / RONDELLE	7.312-278.0	1
6	LUFTKLAPPE / AIR FLAP / VOLET D'ADMIS.D'AIR	5.606-002.0	1
7	KUPPLUNGSTEIL / COUPLING ELEMENT / PIECE D'ACCOUPL.	5.471-060.0	1
8	LAUFRAD / FAN WHEEL / ROUE DE VENTILATEUR	5.600-021.0	1
9	TOLERANZRING D14X8 / TOLERANCE RING / BAGUE	6.343-166.0	1
10	SPANNBAND / BANNER / BANDEROLE	6.388-608.0	2
11	TUCHMANSCHETTE / CLOTH COLLAR / MANCHETTE	5.178-028.0	1
12	HUELSE / SLEEVE / DOUILLE	5.110-306.0	3
13	GUMMIRING / RUBBER RING / RONDELLE CAOUTCHOUC	5.379-011.0	3
14	SCHEIBE 5 / WASHER / RONDELLE	7.312-264.0	3
15	SCHNEIDSCHR. M5X 20 / SELF-TAPPING SCREW / VIS AUTOTARAUDEUSE	6.303-076.0	3
16	GEHAEUSE / HOUSING / BOITIER	5.605-143.0	1

"=> xxxxxx" = bis Werknummer / up to serial No. / jusqu' au No. de fabr. / "xxxxxx =>" = ab Werknummer / from serial No. / a partir du No. de fabr. /

GRUPPE: 5.0 BRENNSTOFFSYSTEM
GROUP: 5.0 FUEL SYSTEM
GRUPPE: 5.0 SYSTEME DE COMBUSTIBLE

A5

HDS 600 C

GRUPPE: 5.0 BRENNSTOFFSYSTEM
GROUP: 5.0 FUEL SYSTEM
GRUPPE: 5.0 SYSTEME DE COMBUSTIBLE

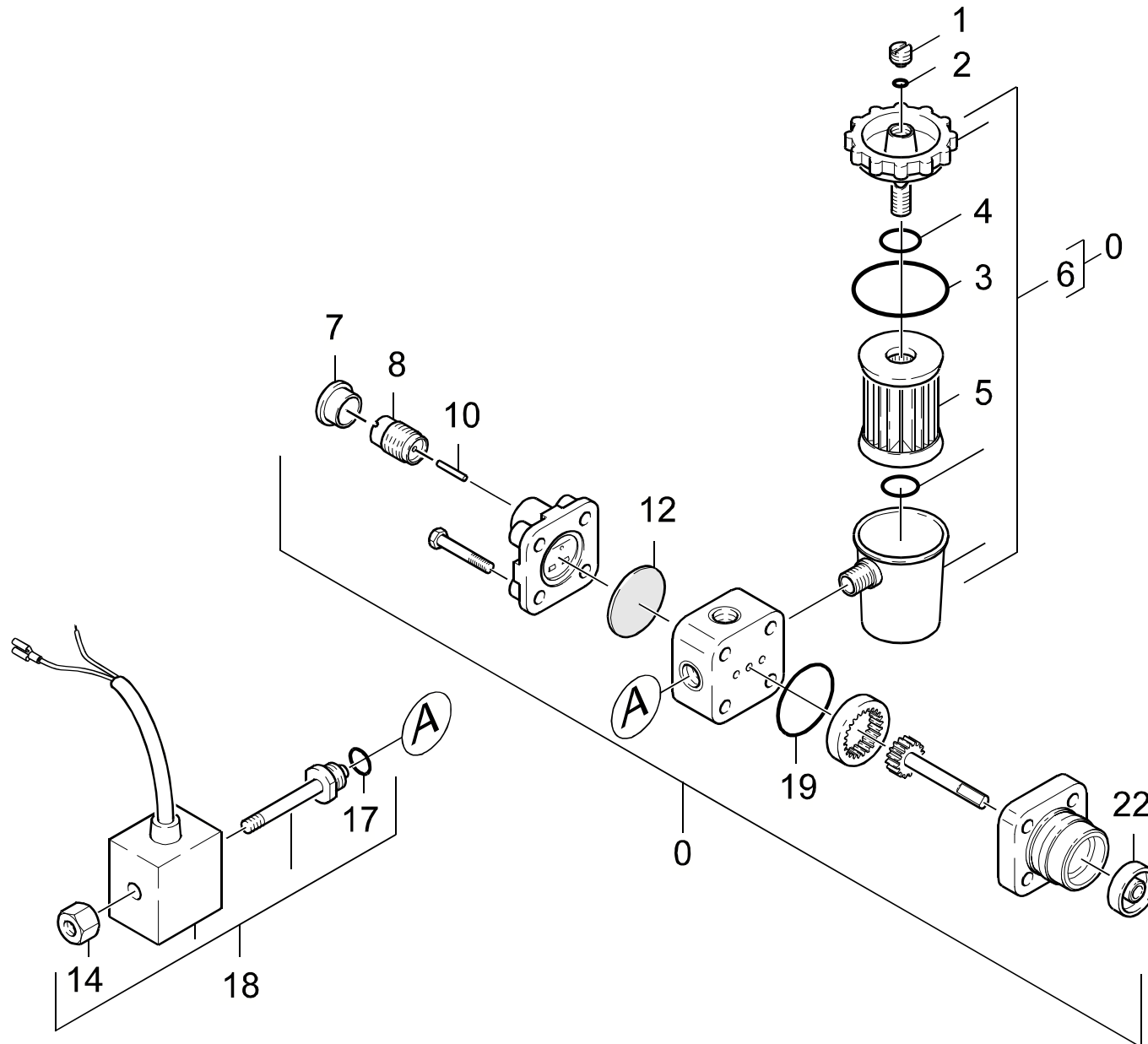

Symbolbeschreibung siehe M16 / symbol description see M16 / désignation de système voir M16 /

GRUPPE: 5.1 BRENNSTOFFPUMPE
GROUP: 5.1 FUEL PUMP
GROUPE: 5.1 POMPE DE COMBUSTIBLE

C5

HDS 600 C

POS. ITM. POS.	BENNENUN G DESCRIPTION DESIGNATION	TEILE-NR. PART-NO. NO.PIECE	STCK QTY. NBR.
0	BRENNSTOFFPUMPE / FUEL PUMP / POMPE DE COMBUSTIBLE	6.472-925.0	1
1	ENTLUEFTUNGSSCHR. / VENT SCREW / VIS D'AIR	6.472-107.0	1
2	O-RING 5,0 X 1,8 / GASKET / BAQUE D'ETANCHEITE	6.472-106.0	1
3	O-RING 32,0 X 1,6 / GASKET / BAQUE D'ETANCHEITE	6.472-111.0	1
4	O-RING 10,0 X 2,4 / GASKET / BAQUE D'ETANCHEITE	6.472-112.0	1
5	FILTEREINSATZ / FILTER CARTRIDGE / CARTOUCHE FILTRANTE	6.472-113.0	1
6	FILTERGEHAEUSE KPL. / FILTER CASE / BATI DE FILTRE	6.472-123.0	1
7	SCHUTZKAPPE / PROTECTIVE CAP / CAPOT PROTECTION	6.472-122.0	1
8	FEDERGEHAEUSE / SPRING HOUSING / BARILLET	6.472-109.0	1
10	STIFT / PIN / CHEVILLE	6.472-108.0	1
12	MEMBRANE / DIAPHRAGM / MEMBRANE	6.472-128.0	1
14	RAENDELMUTTER / KNURLED NUT / ECROU MOLETE	6.472-340.0	1
17	O-RING 12,0 X 1,5 / GASKET / BAQUE D'ETANCHEITE	6.472-125.0	1
18	MAGNETVENTIL KOMPL. / SOLENOID VALVE / ELECTROVANNE	6.472-389.0	1
19	O-RING 28,5 X 1,6 / GASKET / BAQUE D'ETANCHEITE	6.472-120.0	1
22	ACHSENDICHTUNG / SHAFT SEAL / ETOUPAGE D'ESSIEU	6.472-105.0	1

"=> xxxxxx" = bis Werknummer / up to serial No. / jusqu' au No. de fabr. / "xxxxxx =>" = ab Werknummer / from serial No. / a partir du No. de fabr. /

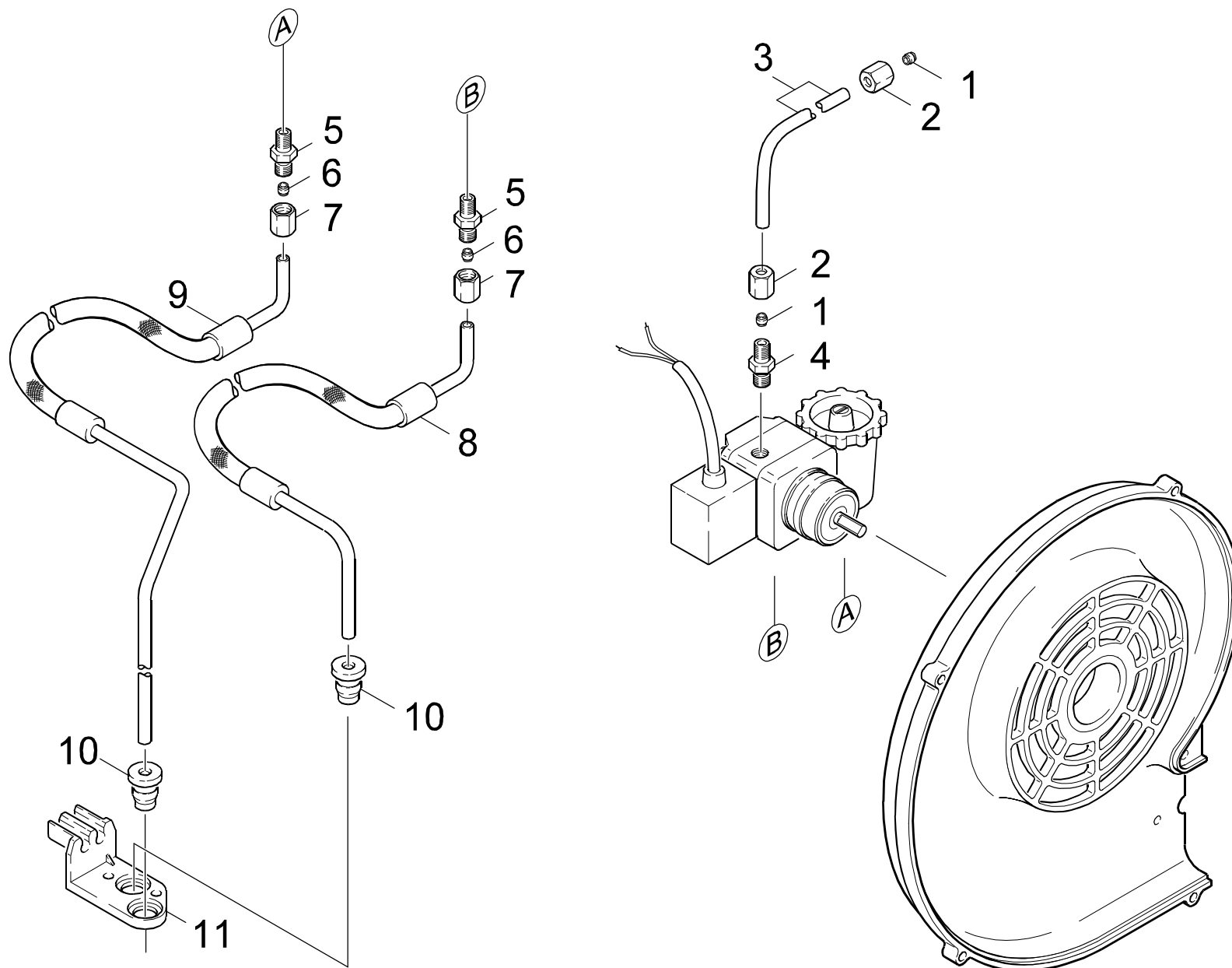

Symbolbeschreibung siehe M16 / symbol description see M16 / désignation de système voir M16 /

GRUPPE: 5.2 BRENNSTOFFLEITUNG
GROUP: 5.2 FUEL PIPE
GRUPPE: 5.2 ALIMENTATION DE COMBUST.

E5

HDS 600 C

POS.	BENNENUNG	TEILE-NR.	STCK
ITM.	DESCRIPTION	PART-NO.	QTY.
POS.	DESIGNATION	NO.PIECE	NBR.
1	SCHNEIDRING D.4 / CUTTING RING / BAGUE COUPANTE	6.389-263.0	2
2	UE-MUTTER A 4-LL / UNION NUT / ECROU RACOURD	6.389-262.0	2
3	LEITUNGSROHR / PIPE / TUBE CONDUCTEUR	5.423-098.0	1
4	SCHRAUBSTUTZEN / SCREW UNION / RACCORD FILETE	6.389-261.0	2
5	STUTZEN 6-L1/8NPT / CONNECTION PIECE / TUBULURE	6.386-181.0	2
6	SCHNEIDRING D 6-L/S / CUTTING RING / BAGUE COUPANTE	6.386-160.0	2
7	UE-MUTTER A 6-L / UNION NUT / ECROU RACOURD	6.386-346.0	2
8	SCHLAUCHLEITUNG / HOSE ASSEMBLY / CONDUITE	6.389-089.0	1
9	SCHLAUCHLEITUNG / HOSE ASSEMBLY / CONDUITE	6.389-165.0	1
11	HALTER / BRACKET / FIXATION	5.042-432.0	1

"=> xxxxxx" = bis Werknummer / up to serial No. / jusqu' au No. de fabr. / "xxxxxx =>" = ab Werknummer / from serial No. / a partir du No. de fabr. /

GRUPPE: 6.0 E-GERAETESCHRANK
GROUP: 6.0 ELECTRIC CONTROL BOX
GRUPPE: 6.0 COFFRET ELECTRIQUE

A6

HDS 600 C

GRUPPE: 6.0 E-GERAETESCHRANK
GROUP: 6.0 ELECTRIC CONTROL BOX
GRUPPE: 6.0 COFFRET ELECTRIQUE

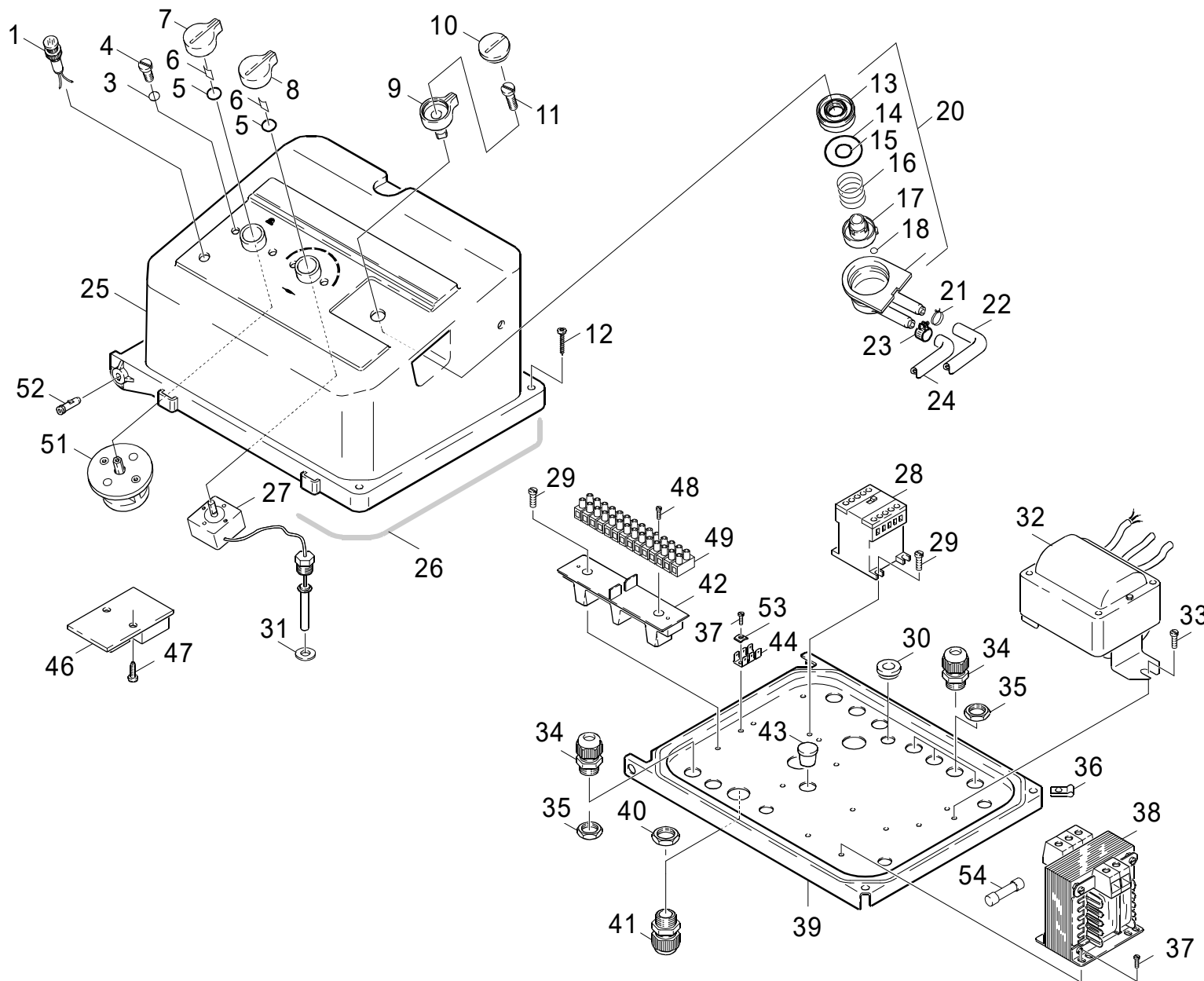

Symbolbeschreibung siehe M16 / symbol description see M16 / désignation de système voir M16 /

GRUPPE: 6.0 E-GERAETESCHRANK
 GROUP: 6.0 ELECTRIC CONTROL BOX
 GROUPE: 6.0 COFFRET ELECTRIQUE

C6

HDS 600 C

POS. ITM. POS.	BENNENNUNG DESCRIPTION DESIGNATION	TEILE-NR. PART-NO. NO.PIECE	STCK QTY. NBR.	POS. ITM. POS.	BENNENNUNG DESCRIPTION DESIGNATION	TEILE-NR. PART-NO. NO.PIECE	STCK QTY. NBR.
1	SIGNALLEUCHE ROT / PILOT LAMP / LAMPE TEMOIN	6.651-184.0	2	36	BLECHMUTTER / NUT / ECROU	6.310-034.0	2
3	DICHTRING / JOINT RING / BAGUE D'ETANCHEITE	5.363-225.0	4	37	SCHNEIDSCHR. M4X 8 / SELF-TAPPING SCREW / VIS AUTOTARAUDEUSE	6.303-017.0	6
4	ZYL.SCHR. M 4X 10 / CHEESE HEAD SCREW / VIS A TETE CYLINDR.	7.306-513.0	4	38	STEUERTRAFO 40VA / TRANSFORMER / TRANSFORMATEUR	6.622-021.0	1
5	O-RING 13,3 X 2,4 / GASKET / BAQUE D'ETANCHEITE	6.362-078.0	1	39	MONTAGEPLATTE / ASSEMBLY PLATE / PLAQUE DE MONTAGE	5.801-097.0	1
6	KLEMMFEDER / SPRING / RESSORT DE FRICTION	6.313-014.0	2	40	GEGENMUTTER PG13,5 / COUNTERNUT / CONTRE-ECROU	6.641-369.0	1
7	GRIFF / HANDLE / POIGNEE	5.321-183.0	1	41	KABELVERSCHR. / CABLE CONNECTOR / RACCORD DE CABLES	6.641-613.0	1
8	GRIFF / HANDLE / POIGNEE	5.321-182.0	1	42	AUFLAGER / SUPPORT / SUPPORT	5.057-036.0	1
9	GRIFF / HANDLE / POIGNEE	5.321-279.0	1	43	VERSCHLUSSTOPFEN / DRAIN PLUG / BOUCHON	6.368-064.0	2
10	STOPFEN / PLUG / BOUCHON	5.132-063.0	1	44	FLACHSTECKER / PLUG / FICHE PLATE	6.641-270.0	1
11	BL.SCHR. ST3,5X25 / SHEET METAL SCREW / VIS A TOLE	7.303-065.0	1	46	IMPULSGEBER / PULSE GENERATOR / CONTACTEUR	6.633-372.0	1
12	BL.SCHR. ST4,8X19 / SHEET METAL SCREW / VIS A TOLE	7.303-078.0	2	47	LINSENSCHR. 3,5X9,5 / OVAL HEAD SCREW / VIS A TETE BOMBEE	6.303-022.0	2
13	DECKEL / COVER / COUVERCLE	5.063-353.0	1	48	BL.SCHR. ST3,5X19 / SHEET METAL SCREW / VIS A TOLE	7.303-064.0	2
14	O-RING 32,0 X 2,5 / GASKET / BAQUE D'ETANCHEITE	6.362-085.0	1	49	KLEMMLEISTE / STRIP TERMINAL / BORNE PLATE	6.643-249.0	1
15	O-RING 12,5 X 2,5 / GASKET / BAQUE D'ETANCHEITE	6.362-515.0	1	50	FUNKENTSTOERFILTER / INTERFERENCE SUPPRESSOR / FILTRE ANTIPARASITE	6.661-091.0	1
16	SCHRAUBENFEDER / HELICAL SPRING / RESSORT CYLINDRIQUE	5.332-236.0	1	51	SCHALTER / SWITCH / INTERRUPTEUR	6.631-081.0	1
17	VENTILSITZ / VALVE SEAT / SIEGE DE SOUPE	5.581-121.0	1	52	BOLZEN / BOLT / BOULON	5.316-223.0	2
18	O-RING 5 X 1,5 / GASKET / BAQUE D'ETANCHEITE	6.362-386.0	1	53	KLEMMSCHEIBE 4 / CLAMPIUNG DISC / DISQUE DE SERRAGE	6.641-804.0	1
20	ERSATZTEILSET / SPARE PARTS KIT / KIT DE PIECES	2.883-091.0	1	54	G-SCHMELZEINSATZ / CARTRIDGE / BOUCHON FUSIBLE	6.644-052.0	1
21	SCHLAUCHSCHELLE / HOSE BAND CLIP / COLLIER DE SERRAGE	6.388-559.0	2				
22	SCHLAUCH DN 7 / HOSE / TUYAU FLEXIBLE	6.388-225.0	3				
23	SCHLAUCHSCHELLE / HOSE BAND CLIP / COLLIER DE SERRAGE	6.388-515.0	2				
24	SCHLAUCH DN 7 / HOSE / TUYAU FLEXIBLE	6.388-194.0	2				
25	HAUBE E-SCHRANK / COVER / CAPOT	5.066-588.0	1				
26	MOOSGUMMISCHNUR / CELLULAR RUBBER CORD / CORDON EN CAOUTCHOUC CELL	6.273-082.0	1				
27	TEMPERATURREGLER / THERMOSTAT / THERMOSTAT	6.685-868.0	1				
28	SCHUETZ / CONTACTOR / CONTACTEUR	6.632-356.0	1				
29	SCHRAUBE M 4X 16 / SCREW / VIS	7.303-033.0	4				
30	GUMMIRING / RUBBER RING / RONDELLE CAOUTCHOUC	5.379-013.0	4				
31	SCHEIBE / WASHER / RONDELLE	5.115-375.0	1				
32	ZUENDTRAFO ET-SATZ / TRANSFORMER / TRANSFORMATEUR	2.883-468.0	1				
33	SCHRAUBE M 5X 8 / SCREW / VIS	7.303-036.0	2				
34	KABELVERSCHR. PG 9 / CABLE CONNECTOR / RACCORD DE CABLES	6.641-355.0	8				
35	GEGENMUTTER PG 9 / COUNTERNUT / CONTRE-ECROU	6.641-366.0	8				

"=> xxxxxx" = bis Werknummer / up to serial No. / jusqu' au No. de fabr. / "xxxxxx =>" = ab Werknummer / from serial No. / a partir du No. de fabr. /

GRUPPE: 7.0 DURCHLAUFERHITZER
GROUP: 7.0 FLOW HEATER
GRUPPE: 7.0 CHAUFFE-EAU RAPIDE

A7

HDS 600 C

GRUPPE: 7.0 DURCHLAUFERHITZER
GROUP: 7.0 FLOW HEATER
GRUPPE: 7.0 CHAUFFE-EAU RAPIDE

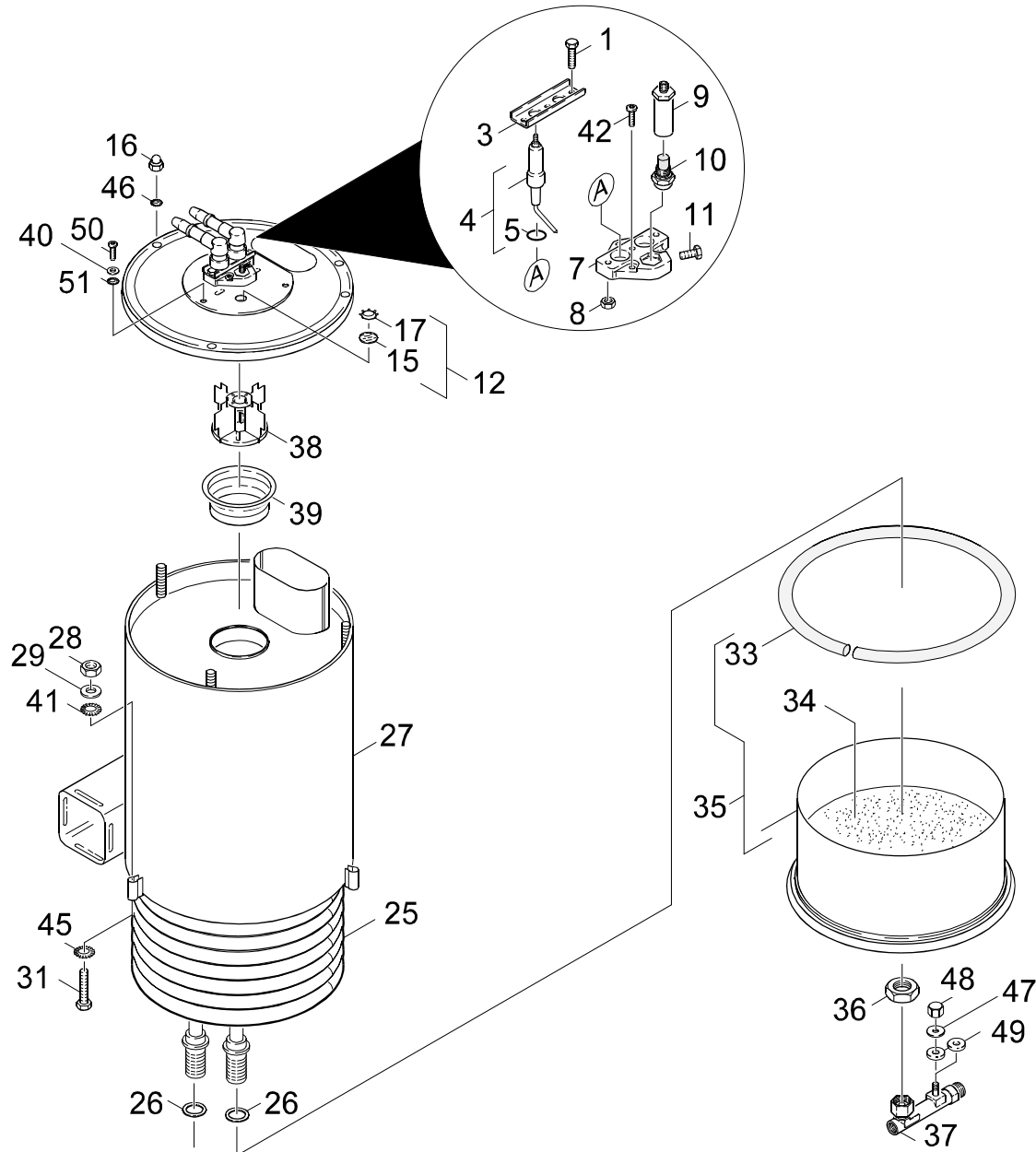

Symbolbeschreibung siehe M16 / symbol description see M16 / désignation de système voir M16 /

GRUPPE: 7.0 DURCHLAUFERHITZER
 GROUP: 7.0 FLOW HEATER
 GROUPE: 7.0 CHAUFFE-EAU RAPIDE

C7

HDS 600 C

POS. ITM. POS.	BENNENNUNG DESCRIPTION DESIGNATION	TEILE-NR. PART-NO. NO.PIECE	STCK QTY. NBR.	POS. ITM. POS.	BENNENNUNG DESCRIPTION DESIGNATION	TEILE-NR. PART-NO. NO.PIECE	STCK QTY. NBR.
1	6KT-SCHR. M 5X 16 / HEXAGONAL HEAD SCREW / VIS HEXAGONAL	7.309-017.0	3	50	BL.SCHR. ST4,8X19 / SHEET METAL SCREW / VIS A TOLE	7.303-078.0	3
3	LASCHE / RETAINER CLIP / ECLISSE	5.004-228.0	1	51	ZAHNSCHEIBE A 5,3 / LOCK WASHER / ROUE PLATE	7.312-172.0	1
4	ERSATZTEILSET / SPARE PARTS KIT / KIT DE PIECES	2.883-083.0	1				
5	DICHTRING 12 X15,5 / JOINT RING / BAGUE D'ETANCHEITE	7.362-004.0	2				
7	KERZENHALTER / SPARK HOLDER / SUPPORT BOUGIE	5.668-001.0	1				
8	6KT-MUTTER M 5 / HEXAGON NUT / ECROU HEXAGONAL	7.311-037.0	3				
9	DUESENHALTER / NOZZLE HOLDER / PORTE - BUSE	5.667-042.0	1				
10	DUESE / NOZZLE / BUSE	6.415-565.0	1				
11	ZYL.SCHR. M 5X 12 / CHEESE HEAD SCREW / VIS A TETE CYLINDR.	7.306-443.0	1				
12	DECKEL D.K. / COVER / COUVERCLE	4.654-133.0	1				
15	GLASSCHEIBE / GLASS PANE / VITRE	6.278-018.0	1				
16	HUTMUTTER M 6 / CAP NUT / ECROU BORGNE	7.311-380.0	3				
17	ZACKENRING / RING / ANNEAU	6.343-165.0	1				
18	DECKEL D.K. / COVER / COUVERCLE	5.654-038.0	1				
25	HEIZSCHLANGE / HEATING COIL / SERPENTIN	4.680-127.0	1				
26	PROFILDICHTUNG / SEAL / ETOUPE PROFILE	5.365-068.0	2				
27	AUSSENMANTEL / OUTER JACKET / ENVELOPPE	4.652-065.0	1				
28	6KT-MUTTER M 8 / HEXAGON NUT / ECROU HEXAGONAL	7.311-510.0	3				
29	SCHEIBE 8 / WASHER / RONDELLE	7.312-004.0	3				
31	FL.RD.SCHR. M 8X 55 / SAUCER-HEAD SCREW / BOULON A TETE BOMBEE	7.303-165.0	3				
33	DICHTSCHNUR / SEAL STRING / CORDE DE BOURRAGE	6.366-009.0	1				
34	STAMPFMASSE 8KG / REFRACTORY MATERIAL / PISE REFRACT. DAME	2.889-061.0	1				
35	BODEN D.K. / BOTTOM / FOND	4.655-044.0	1				
36	6KT-MUTTER M22X1,5 / HEXAGON NUT / ECROU HEXAGONAL	7.311-155.0	2				
37	KNOTENSTUECK / MANIFOLD / FERRURE NODALE	4.427-123.0	1				
38	BRENNEREINSATZ / BURNER CAGE / BRULEUR CAGE	4.663-077.0	1				
39	BRENNERTEIL / BURNER PART / PIECE DE BRULEUR	5.664-179.0	1				
40	SCHEIBE 5 / WASHER / RONDELLE	7.312-002.0	3				
41	ZAHNSCHEIBE A 8,4 / LOCK WASHER / ROUE PLATE	7.312-166.0	3				
42	SCHRAUBE M 5X 16 / SCREW / VIS	7.303-039.0	3				
45	ZAHNSCHEIBE A 13,0 / LOCK WASHER / ROUE PLATE	7.312-169.0	3				
46	ZAHNSCHEIBE A 6,4 / LOCK WASHER / ROUE PLATE	7.312-167.0	3				
47	UNTERLAGE / SPACER / COUSSINET	5.378-100.0	2				
48	HUTMUTTER M 8 / CAP NUT / ECROU BORGNE	7.311-337.0	1				
49	SCHEIBE 8 / WASHER / RONDELLE	7.312-277.0	1				

"=> xxxxxx" = bis Werknummer / up to serial No. / jusqu' au No. de fabr. / "xxxxxx =>" = ab Werknummer / from serial No. / a partir du No. de fabr. /

GRUPPE: 8.0 SCHWIMMERKASTEN
GROUP: 8.0 FLOAT CHEST
GRUPPE: 8.0 BOITE DU FLOTTEUR

A8

HDS 600 C

GRUPPE: 8.0 SCHWIMMERKASTEN
GROUP: 8.0 FLOAT CHEST
GRUPPE: 8.0 BOITE DU FLOTTEUR

Ersatzteile unter www.gluesing.net

GRUPPE: 8.0 SCHWIMMERKASTEN
GROUP: 8.0 FLOAT CHEST
GRUPPE: 8.0 BOITE DU FLOTTEUR

B8

HDS 600 C

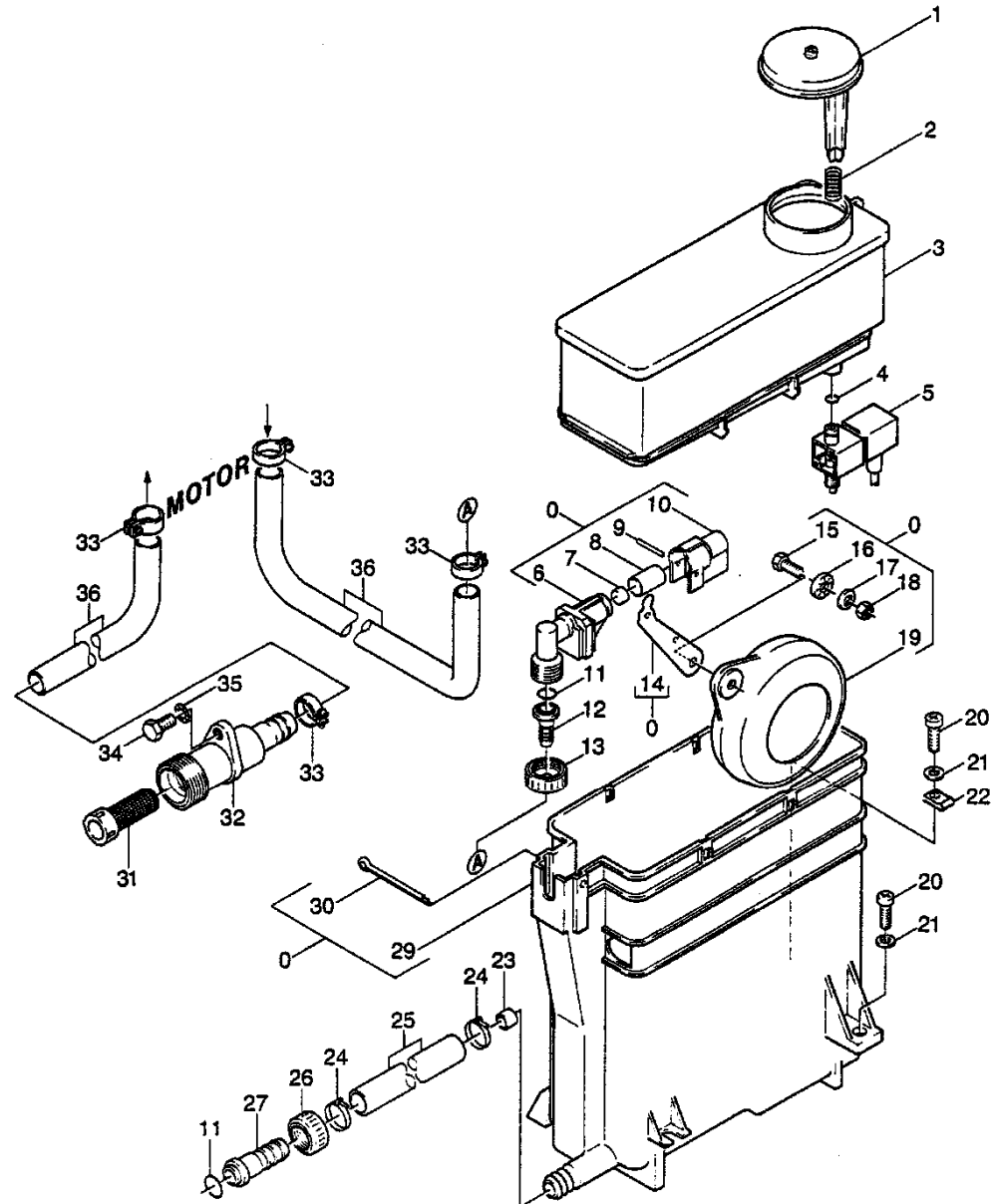

Symbolbeschreibung siehe M16 / symbol description see M16 / désignation de système voir M16 /

GRUPPE: 8.0 SCHWIMMERKASTEN
 GROUP: 8.0 FLOAT CHEST
 GROUPE: 8.0 BOITE DU FLOTTEUR

C8

HDS 600 C

POS. ITM. POS.	BENNENNUNG DESCRIPTION DESIGNATION	TEILE-NR. PART-NO. NO.PIECE	STCK QTY. NBR.	POS. ITM. POS.	BENNENNUNG DESCRIPTION DESIGNATION	TEILE-NR. PART-NO. NO.PIECE	STCK QTY. NBR.
0	SCHWIMMERVERTIL / FLOAT VALVE / SOUPAPE A FLOTTEUR	3.593-063.0	1	36	SCHLAUCH DN16 / HOSE / TUYAU FLEXIBLE	6.388-719.0	1
1	DECKEL / COVER / COUVERCLE	5.063-357.0	1		ALS METERWARE BESTELLEN/TO ORDER AS CUT		
2	SCHRAUBENFEDER / HELICAL SPRING / RESSORT CYLINDRIQUE	5.332-001.0	1		GOODS/COMMANDE COMME MARCHANDISE AU METRE		
3	BEHAELTER / TANK / BAC	4.070-123.0	1				
4	O-RING 6,0 X 2,0 / GASKET / BAQUE D'ETANCHEITE	6.362-113.0	1				
5	MAGNETVENTIL / SOLENOID VALVE / ELECTROVANNE	6.685-845.0	1				
6	VENTILGEHAEUSE / VALVE HOUSING / CORPS DE SOUPAPE	5.587-134.0	1				
7	FLACHDICHTUNG / GASKET / GARNITURE PLATE	5.364-095.0	1				
8	VENTILBOLZEN / VALVE PIN / BOULON DE SOUPAPE	5.584-026.0	1				
9	BOLZEN 3,0X 25 / BOLT / BOULON	7.316-004.0	1				
10	SCHUTZTEIL / PROTECTION PART / PARTIE PROTECTEUR	5.394-066.0	1				
11	O-RING 13,3 X 2,4 / GASKET / BAQUE D'ETANCHEITE	6.362-078.0	2				
12	SCHLAUCHNIPPEL / HOSE STEM / RACCORD DE FLEXIBLE	5.443-224.0	1				
13	MUTTER R 3/4Z / NUT / ECROU	5.310-061.0	1				
14	HEBEL / LEVER / LEVIER	5.481-029.0	1				
15	SCHRAUBE M 6X 20 / SCREW / VIS	7.306-194.0	1				
16	SCHEIBE / WASHER / RONDELLE	5.115-158.0	1				
17	SCHEIBE 6 / WASHER / RONDELLE	7.312-279.0	1				
18	6KT-MUTTER M 6 / HEXAGON NUT / ECROU HEXAGONAL	7.311-422.0	1				
19	SCHWIMMER / FLOAT / FLOTTEUR	5.585-014.0	1				
20	BL.SCHR. ST4,8X19 / SHEET METAL SCREW / VIS A TOLE	7.303-078.0	2				
21	SCHEIBE 5 / WASHER / RONDELLE	7.312-278.0	2				
22	SCHNAPPMUTTER 4,8 / SNAP NUT / ECROU A ENCLANCH.	6.310-028.0	1				
23	BUCHSE / BUSH / DOUILLE	5.112-189.0	1				
24	KABELBAND 8-210 / CABLE TIE / PROTECT. DE CABLE	6.641-474.0	2				
25	SCHLAUCH 19X4X0,2M / HOSE / TUYAU FLEXIBLE	6.388-775.0	1				
26	MUTTER / NUT / ECROU	5.310-062.0	1				
27	SCHLAUCHNIPPEL / HOSE STEM / RACCORD DE FLEXIBLE	5.443-312.0	1				
29	BEHAELTER / TANK / BAC	5.070-099.0	1				
30	SPLINT 4,0X 50 / COTTER / GOUPILLE FENDUE	7.316-432.0	1				
31	SIEB / STRAINER / CREPINE	6.414-282.0	1				
32	KNOTENSTUECK / MANIFOLD / FERRURE NODALE	5.427-123.0	1				
33	SCHLAUCHSCHELLE / HOSE BAND CLIP / COLLIER DE SERRAGE	6.388-547.0	2				
34	6KT-SCHR. M 6X 12 / HEXAGONAL HEAD SCREW / VIS HEXAGONAL	7.309-008.0	1				
35	ZAHNSCHEIBE A 6,4 / LOCK WASHER / ROUE PLATE	7.312-167.0	1				

"=> xxxxxx" = bis Werknummer / up to serial No. / jusqu' au No. de fabr. / "xxxxxx =>" = ab Werknummer / from serial No. / a partir du No. de fabr. /

GRUPPE: 9.0 SICHERHEITSBLOCK
GROUP: 9.0 SAFETY SYSTEM
GRUPPE: 9.0 BLOC DE SECURITE

A9

HDS 600 C

GRUPPE: 9.0 SICHERHEITSBLOCK
GROUP: 9.0 SAFETY SYSTEM
GRUPPE: 9.0 BLOC DE SECURITE

Ersatzteile unter www.gluesing.net

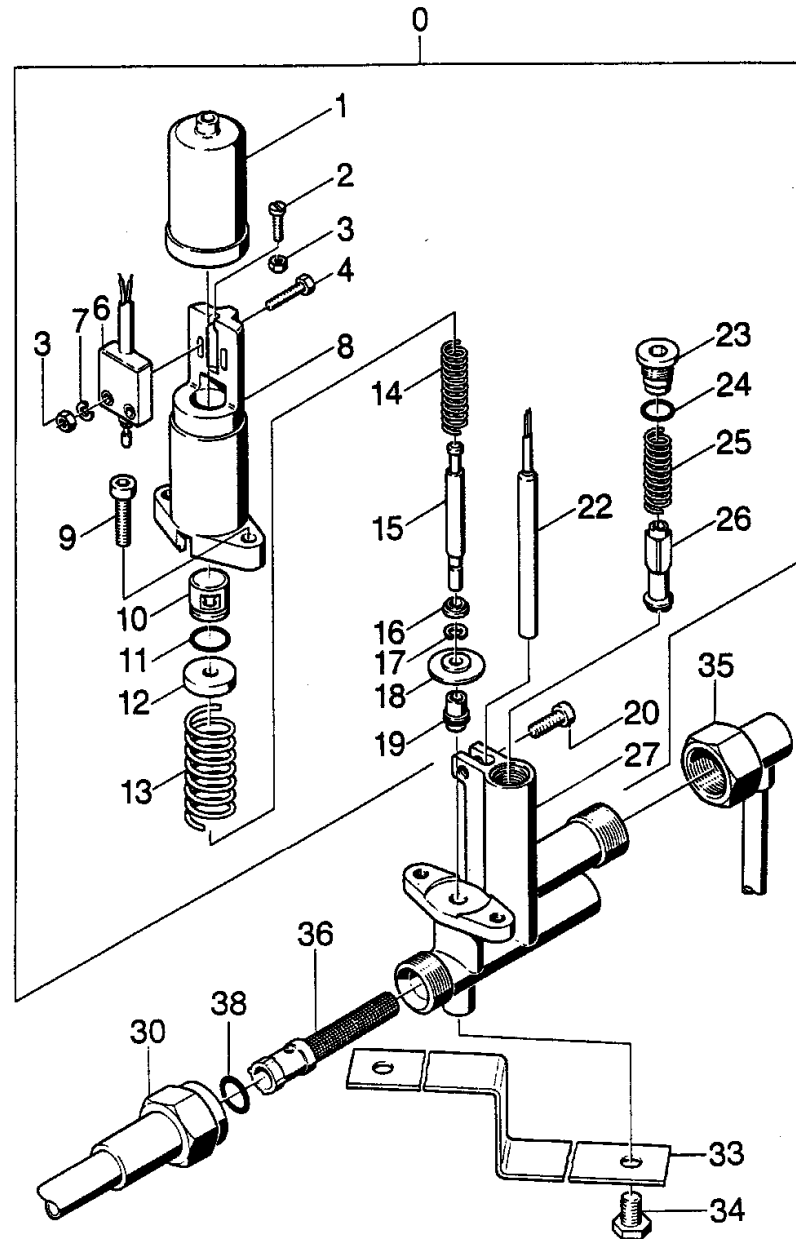

Symbolbeschreibung siehe M16 / symbol description see M16 / désignation de système voir M16 /

GRUPPE: 9.0 SICHERHEITSBLOCK
 GROUP: 9.0 SAFETY SYSTEM
 GROUPE: 9.0 BLOC DE SECURITE

C9

HDS 600 C

POS. ITM. POS.	BENNENNUNG DESCRIPTION DESIGNATION	TEILE-NR. PART-NO. NO.PIECE	STCK QTY. NBR.	POS. ITM. POS.	BENNENNUNG DESCRIPTION DESIGNATION	TEILE-NR. PART-NO. NO.PIECE	STCK QTY. NBR.
0	SICHERHEITSBLOCK / SAFETY SYSTEM / BLOC DE SECURITE	4.749-077.0	1	38	ERSATZTEILSET / SPARE PARTS KIT / KIT DE PIECES	2.880-296.0	1
1	SCHUTZTEIL / PROTECTION PART / PARTIE PROTECTEUR	5.394-060.0	1				
2	SCHRAUBE M 3X 16 / SCREW / VIS	7.306-054.0	1				
3	6KT-MUTTER M 3 / HEXAGON NUT / ECROU HEXAGONAL	7.311-000.0	3				
4	6KT-SCHR. M 3X 20 / HEXAGONAL HEAD SCREW / VIS HEXAGONAL	7.304-352.0	2				
6	MIKROSCHALTER / MICRO SWITCH / MICRORUPTEUR	6.631-125.0	1				
7	FEDERRING B 3 / SPRING WASHER / RONDELLE GROWER	7.313-000.0	2				
8	GEHAEUSE / HOUSING / BOITIER	5.060-099.0	1				
9	ZYL.SCHR. M 6X 25 / CHEESE HEAD SCREW / VIS A TETE CYLINDR.	7.306-023.0	2				
10	KOLBEN / PISTON / PISTON	5.553-046.0	1				
11	O-RING 12,0 X 2,0 / GASKET / BAQUE D'ETANCHEITE	6.362-169.0	1				
12	BUCHSE / BUSH / DOUILLE	5.112-207.0	1				
13	SCHRAUBENFEDER / HELICAL SPRING / RESSORT CYLINDRIQUE	5.332-069.0	1				
14	SCHRAUBENFEDER / HELICAL SPRING / RESSORT CYLINDRIQUE	5.332-070.0	1				
15	STANGE / BAR / TIGE	5.107-023.0	1				
16	BUCHSE / BUSH / DOUILLE	5.112-094.0	1				
17	S-SCHEIBE 4 / LOCK WASHER / RONDELLE D'ARRET	7.343-203.0	1				
18	SCHEIBE / WASHER / RONDELLE	5.115-147.0	1				
19	KOLBEN / PISTON / PISTON	4.553-025.0	1				
20	LINSENSCHR. M 5X 16 / OVAL HEAD SCREW / VIS A TETE BOMBEE	7.306-308.0	1				
22	ERSATZREEDSCHALTER / SPARE REED SWITCH / INTERRUPT.REED DE RESERVE	2.880-194.0	1				
23	FORMSCHRAUBE / FORM SCREW / VIS	5.305-162.0	1				
24	O-RING 10 X 1,5 / GASKET / BAQUE D'ETANCHEITE	6.362-482.0	1				
25	SCHRAUBENFEDER / HELICAL SPRING / RESSORT CYLINDRIQUE	5.332-057.0	1				
26	KOLBEN / PISTON / PISTON	4.553-022.0	1				
27	GEHAEUSE / HOUSING / BOITIER	5.060-303.0	1				
30	HD-SCHLAUCH DN 8 / HIGH PRESSURE HOSE / TUYAU FLEXIBLE HAUTE PRE.	6.388-910.0	1				
33	HALTER / BRACKET / FIXATION	5.042-468.0	1				
34	6KT-SCHR. M 8X 12 / HEXAGONAL HEAD SCREW / VIS HEXAGONAL	7.304-394.0	1				
35	ROHRLEITUNG / PIPELINES / CONDUITE	4.421-064.0	1				
36	SIEB / STRAINER / CREPINE	6.414-327.0	1				

"=> xxxxxx" = bis Werknummer / up to serial No. / jusqu' au No. de fabr. / "xxxxxx =>" = ab Werknummer / from serial No. / a partir du No. de fabr. /

GRUPPE: 10.0ZUBEHOER / GRUPPE: 10
GROUP: 10.0ACCESSORIES / GROUP: 10
GRUPPE: 10.0ACCESSOIRES / GROUPE: 10

A10

HDS 600 C

GRUPPE: 10.0ZUBEHOER
GROUP: 10.0ACCESSORIES
GRUPPE: 10.0ACCESSOIRES

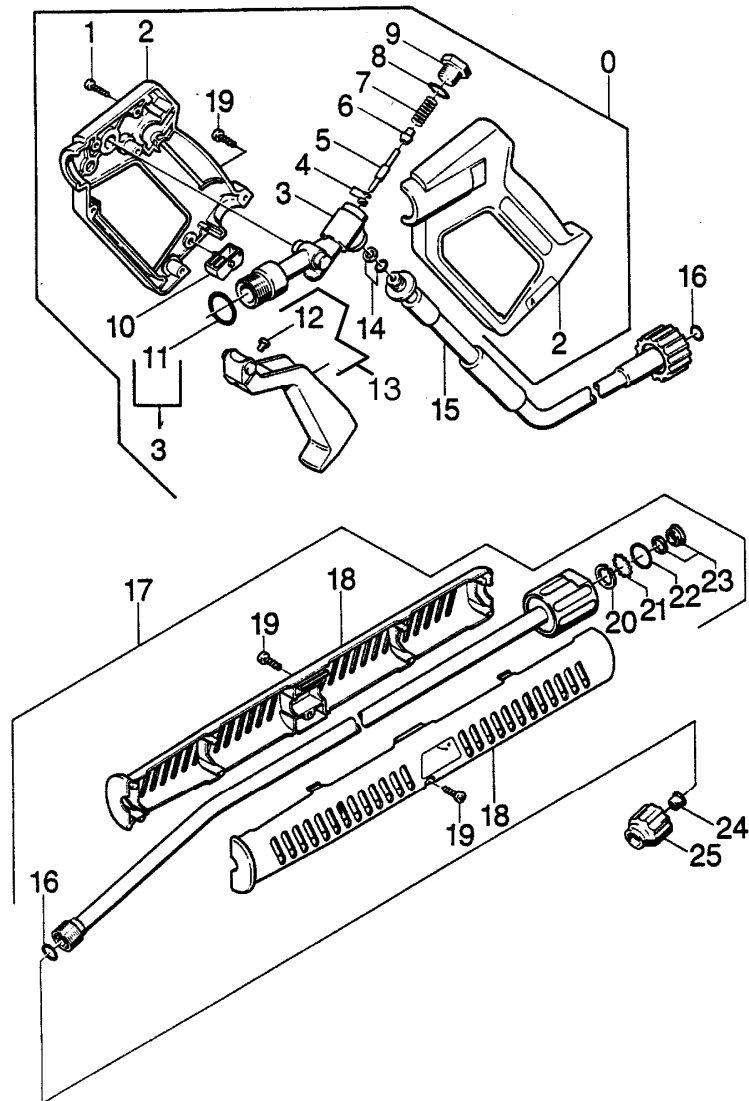

Symbolbeschreibung siehe M16 / symbol description see M16 / désignation de système voir M16 /

GRUPPE: 10.0ZUBEHOER / GRUPPE: 10
GROUP: 10.0ACCESSORIES / GROUP: 10
GROUPE: 10.0ACCESSOIRES / GROUPE: 10

C10

HDS 600 C

POS. ITM. POS.	BENNENUNG DESCRIPTION DESIGNATION	TEILE-NR. PART-NO. NO.PIECE	STCK QTY. NBR.
0	HANDSPRITZPISTOLE / TRIGGER GUN / POIGNEE PISTOLET	4.775-080.0	1
1	LINSENSCHR. 4,2X22 / OVAL HEAD SCREW / VIS A TETE BOMBEE	6.303-024.0	5
2	GRIFFPAAR / HANDLES / BRANCHES POIGNEE	5.321-230.0	1
3	KNOTENSTUECK / MANIFOLD / FERRURE NODALE	4.427-131.0	1
4	O-RING KPL./1ST.-R. / GASKET / BAQUE D'ETANCHEITE	6.362-571.0	1
5	STANGE / BAR / TIGE	5.107-097.0	1
6	VENTILTELLER / VALVE DISC / TETE DE SOUPAPE	5.582-084.0	1
7	SCHRAUBENFEDER / HELICAL SPRING / RESSORT CYLINDRIQUE	5.332-157.0	1
8	O-RING 12,42X 1,78 / GASKET / BAQUE D'ETANCHEITE	6.362-584.0	1
9	VERSCHLUSSSCHRAUBE / CLOSING SCREW / VIS DE FERMETURE	5.411-067.0	1
10	HEBEL / LEVER / LEVIER	5.481-052.0	1
11	O-RING 17,12X 2,62 / GASKET / BAQUE D'ETANCHEITE	6.362-496.0	1
12	GEW.STIFT M 8X 16 / THREADED PIN / VIS SANS TETE	7.307-417.0	1
13	HEBEL / LEVER / LEVIER	4.481-050.0	1
14	O-RING KPL./1ST.-R. / GASKET / BAQUE D'ETANCHEITE	6.363-115.0	1
15	HD-SCHLAUCH DN 6 / HIGH PRESSURE HOSE / TUYAU FLEXIBLE HAUTE PRE.	6.389-056.0	1
16	ERSATZTEILSET / SPARE PARTS KIT / KIT DE PIECES	2.880-296.0	1
17	STRAHLROHR KPL. / JET PIPE / LANCE D'INCENDIE	4.760-550.0	1
18	GRIFF / HANDLE / POIGNEE	5.321-150.0	2
19	LINSENSCHR. 4,2X16 / OVAL HEAD SCREW / VIS A TETE BOMBEE	6.303-025.0	3
20	DICHTRING 12X1,5 / JOINT RING / BAGUE D'ETANCHEITE	6.362-529.0	1
21	KUGEL 4,0 KL3 / BALL / BOULE	7.401-921.0	12
22	O-RING 17,0 X 1,5 / GASKET / BAQUE D'ETANCHEITE	6.362-524.0	1
23	NUTRING KPL.1ST.R. / GROOVED RING / JOINT A LEVRES	6.362-532.0	1
24	POWERDUESE 25045 / POWER NOZZLE / BUSE	2.883-398.0	1
25	VERSCHRAUBUNGSTEIL / SCREW UNION PART / PIECE (RACCORD A VIS)	5.401-129.0	1

"=> xxxxxx" = bis Werknummer / up to serial No. / jusqu' au No. de fabr. / "xxxxxx =>" = ab Werknummer / from serial No. / a partir du No. de fabr. /

Bestellhinweis

Bei Ihrer Bestellung sind unbedingt anzugeben :

1.	2.	3.	4.	5.
Gerätetyp Machine model Type d'appareils	Herstell-Nr. Serial-No. No. de série	Benennung Description Désignation	Teile-Nr. Part No. Référence	Stückzahl Piece No. Quantité



**siehe Typenschild
see name-plate
voir plaque signalétique**



**siehe Ersatzteilliste
see spare parts list
voir liste des pièces de rechange**

- Die Ersatzteile, welche als Meterware geliefert werden, sind auf Einbaulänge selbst zu kürzen. Ebenso sind die Stückzahlen in den jeweiligen Gruppen als Mindestbestellmengen = 1m angegeben und können je nach Bedarf auf weitere volle Meterzahlen erhöht und bestellt werden.
- Spare Parts which are delivered as cut goods have to be shortened to installation length. The quotation of quantity in each group refers to the minimum order quantity = 1m and may be ordered and raised to further full metre-values according to demand
- Les pièces de rechange qui sont livrées comme marchandise au mètre sont à raccourcir selon la longueur d'installation. Les indications de quantité dans chaque group se réfèrent à des valeurs de mètre de plus.
- Diese Ersatzteilliste erscheint in gedruckter Form sowie als Mikrofiche. Bei Querverweisen bezieht sich die Angabe "Seitenzahl" auf die gedruckte Ersatzteilliste und die Angabe "Bildtafel" auf die Mikrofilmausgabe.
- This spare parts list is published both in printed form and as a microfiche. In the cross-references, "page number" refers to the printed spare parts list and "display table" to the microfilm edition.
- Cette liste de pièces de rechange est aussi bien imprimée que publiée sous forme de microfiche. Les indications transversales renvoient au "numéro de page" sur la liste imprimée des pièces de rechange et à la "planche" sur la microfiche.

Bitte beachten Sie, daß der Teileumfang dieser Ersatzteilliste nicht unbedingt dem Lieferumfang Ihres Gerätes entspricht.

For your information: It could be that certain parts quoted in this spare parts list were not included with the machine delivery.

Pour votre information: il se peut que certaines pièces détachées mentionnées sur la liste ne vous aient pas été livrées avec l'appareil.

Die in dieser Ersatzteilliste nicht aufgeführten Einzelteile, bestellen Sie bitte direkt beim Vertragskundendienst des jeweiligen Herstellers.

Please order the individual parts not included in this assembly directly with the contract aftersales service of the manufacturer in question.

Veillez s'il vous plaît, commander les pièces détachées qui ne sont indiquées dans notre liste des pièces détachées, directement auprès du service après-vente des fabricants en question.

Bei Bestellung von lackierten Teilen, welche in der Ersatzteilliste nicht in verschiedenen Farben ausgewiesen sind, ist zusätzlich die Farbnummer oder Farbe mit anzugeben. Diese finden Sie auf dem Typenschild oder Farbschild Ihres Gerätes.

Upon ordering of varnished parts which are not mentioned in the spare parts list as parts with different colors, kindly additionally mention the number of the color. It can be seen on the type plate of the color plate of your machine.

Commandant des parts vernissés qui ne sont pas mentionnés comme parts avec une couleur différente dans la liste des pièces détachées, veuillez mentionner de plus le numéro de la couleur. Il se trouve sur la plaque signalétique ou la plaque de couleur de votre machine.

Auflistungen von Einzelteilen bei Ersatzteil - u. Pumpensets sind in der Reihe "16" einzusehen, bzw. direkt unter dem entsprechenden Set aufgelistet.

Listings of single parts upon spare parts kits and pump kits can be seen in row "16" or directly listed below the corresponding kit.
Des établissements des pièces détachées en ce qui concerne les kits des pièces de rechange et les kits de pompes, peuvent être vus à la ligne "16" ou ils sont répertoriés directement au-dessous du jeu correspondant.

Technische Änderungen im Rahmen der Weiterentwicklung sowie das Recht der ausschließlichen Auswertung unseres geistigen Eigentums behalten wir uns vor. Vervielfältigung und Nachdruck nur mit Genehmigung und Urheberhinweis möglich.

We reserve the right to make technical changes in the course of development work and the right to make exclusive use of our intellectual property. This spare parts list may be duplicated or reprinted only with our approval and with acknowledgement of our copyright.

Nous nous réservons le droit de toutes modifications techniques dans le cadre du perfectionnement des mises au point ainsi que le droit de la mise en valeur exclusive de notre propriété intellectuelle. Polycopie et reproduction exclusivement après accord et avec mention de l'auteur.

INDEX

M16

HDS 600 C

GRUPPE:	1.0 EINZELTEILE	A1-C1	GRUPPE:	9.0 SICHERHEITSBLOCK	A9-C9
GROUP:	1.0 PIECE PARTS		GROUP:	9.0 SAFETY SYSTEM	
GRUPPE:	1.0 PIECES CONSTITUANTES		GRUPPE:	9.0 BLOC DE SECURITE	
GRUPPE:	2.0 PUMPENSATZ	A2-G2	GRUPPE:	10.0 ZUBEHOER	A10-C10
GROUP:	2.0 PUMP SET		GROUP:	10.0 ACCESSORIES	
GRUPPE:	2.0 JEU (ENSEMBLE) DE POMPE		GRUPPE:	10.0 ACCESSOIRES	
GRUPPE:	3.0 MOTOR	A3-C3			
GROUP:	3.0 MOTOR				
GRUPPE:	3.0 MOTEUR				
GRUPPE:	4.0 GEBLAESE	A4-C4			
GROUP:	4.0 BLOWER				
GRUPPE:	4.0 VENTILATEUR				
GRUPPE:	5.0 BRENNSTOFFSYSTEM	A5-E5			
GROUP:	5.0 FUEL SYSTEM				
GRUPPE:	5.0 SYSTEME DE COMBUSTIBLE				
GRUPPE:	6.0 E-GERAETESCHRANK	A6-C6			
GROUP:	6.0 ELECTRIC CONTROL BOX				
GRUPPE:	6.0 COFFRET ELECTRIQUE				
GRUPPE:	7.0 DURCHLAUFERHITZER	A7-C7			
GROUP:	7.0 FLOW HEATER				
GRUPPE:	7.0 CHAUFFE-EAU RAPIDE				
GRUPPE:	8.0 SCHWIMMERKASTEN	A8-C8			
GROUP:	8.0 FLOAT CHEST				
GRUPPE:	8.0 BOITE DU FLOTTEUR				



BEISPIEL: VERSION 1
EXAMPLE: VERSION 1
EXEMPLE: VERSION 1

3.0

BEISPIEL: SIEHE IN GRUPPE 3
EXAMPLE: SEE IN GROUP 3
EXEMPLE: VOIR EN GROUPE 3



WICHTIGER HINWEIS
IMPORTANT REMARK
REMARQUAGE IMPORTANT

BESTELLHINWEIS SIEHE M15
EXAMPLE ORDER SEE M15
EXEMPLE DE COMMANDE VOIR M15

VARIANTENÜBERSICHT SIEHE L16
VARIANTS SURVEY SEE L16
VUE D'ENSEMBLE DE VARIANTS VOIR L16