

TABLE OF CONTENTS - CHAPTER 2

Main Broom	2-2
Side Brooms and Deflector	2-4
Doors, Flaps, & Seals	2-6
Side Cover & Battery Pan	2-8
Hopper	2-9
Forward/Reverse Pedal	2-10
Console Assembly	2-12
Filter System	2-14
Drive Compartment & Seat	2-16
Steering & Drive	2-18
Wheel Lock	2-20
Power Panel	2-22
Instrument Panel	2-24
Decals	2-26

MAIN BROOM - PARTS LIST

<u>KEY NO.</u>	<u>PART NUMBER</u>	<u>DESCRIPTION</u>	<u>QTY.</u>
1	8-60-00161	PULLEY, REVERSE IDLER	1
2	8-03-04295	ARM, R.H.	1
3	2-00-00420	WASHER, 1/2 ID X 1 OD X .06	4
4	2-00-00532	RING, BEARING RETAINER	2
5	2-00-03306	BALL BEARING	1
6	2-00-05244	CARRIAGE BOLT, 1/2-13 X 2.0	1
7	8-75-01147	SPACER, MAIN BROOM IDLER	1
8	2-00-02049	BEARING	2
9	2-00-00427	WASHER, .50 ID X 1.0 OD X .06	1
10	7-60-00167	PULLEY	1
11	2-00-02243	KEY	2
12	8-16-07344	COVER	1
13	2-00-00405	FLAT WASHER, 1.063 x .531 x .094	1
14	2-00-02371	NUT, 1/2-13	2
15	2-00-00208	SCREW, 5/16-18 x .750 HHC	1
16	2-00-00530	LOCK WASHER, 5/16"	1
17	7-09-01057	BUSHING, BRUSH LIFT	1
18	8-15-01002	COLLAR, W/SETSCREW	1
19	8-70-05291	SHAFT, BROOM	1
20	8-33-09062	WELDMENT, MAIN BROOM HUB	1
21	8-81-00166	WELDMENT, MAIN BROOM SUPPORT	1
22	8-41-05076	LEVER	1
23	2-10-01336	SPRING	1
24	2-00-00237	SCREW, HHC 3/8-16 x 3.00	1
25	8-39-00003	KNOB	1
26	2-00-03855	CARRAGE BOLT, 3/8-16 X 1.0"	2
27	2-00-02310	LOCK WASHER, 3/8" HELICAL SPRING	2
28	2-00-02360	NUT, 3/8-16 HEX	2
29	2-00-02293	WASHER	1
30	2-00-02312	LOCK WASHER, 1/2"	1
31	2-00-03382	WASHER, SPRING	1
32	0782-110	MOTOR (36 VDC 1/2 HP 1200 RPM)	1
33	7-60-00166	PULLEY, MOTOR	1
34	2-00-02243	KEY	1
35	8-33-09059	IDLER HUB (WELDMENT)	1
36	2-00-03158	SPACER	2
37	2-00-03306	BALL BEARING	2
38	8-03-04296	WELDMENT, L.H. BROOM ARM	1
39	2-00-02616	BOLT, 1/2-13 FIN. HEX HEAD	1
40	8-08-00766	BRACKET	1
41	2-00-03589	COLLAR, SET SCREW	1
42	2-00-05259	BELT, BROOM DRIVE	1
43	2-00-04345	TYRAP	1
44	2-00-03829	LOCK WASHER, 3/8 INT./EXT. TOOTH	1
45	7-39-00033	KNOB, 3/8-16 ADJUSTABLE HANDLE	1
46	2-00-04801	FLAT WASHER, 1.00 x .39 x .06	1
47	2-00-00221	BOLT, 1/4-20 x 3/4 FIN. HEX HEAD	4
48	2-00-00518	LOCK WASHER, 1/4" HELICAL SPRING	4
49	2-00-04708	TERMINAL, A1 FEMALE	1
50	2-00-05183	TERMINAL, A2 MALE	1

C0449-1/3-04

MAIN BROOM - EXPLODED VIEW

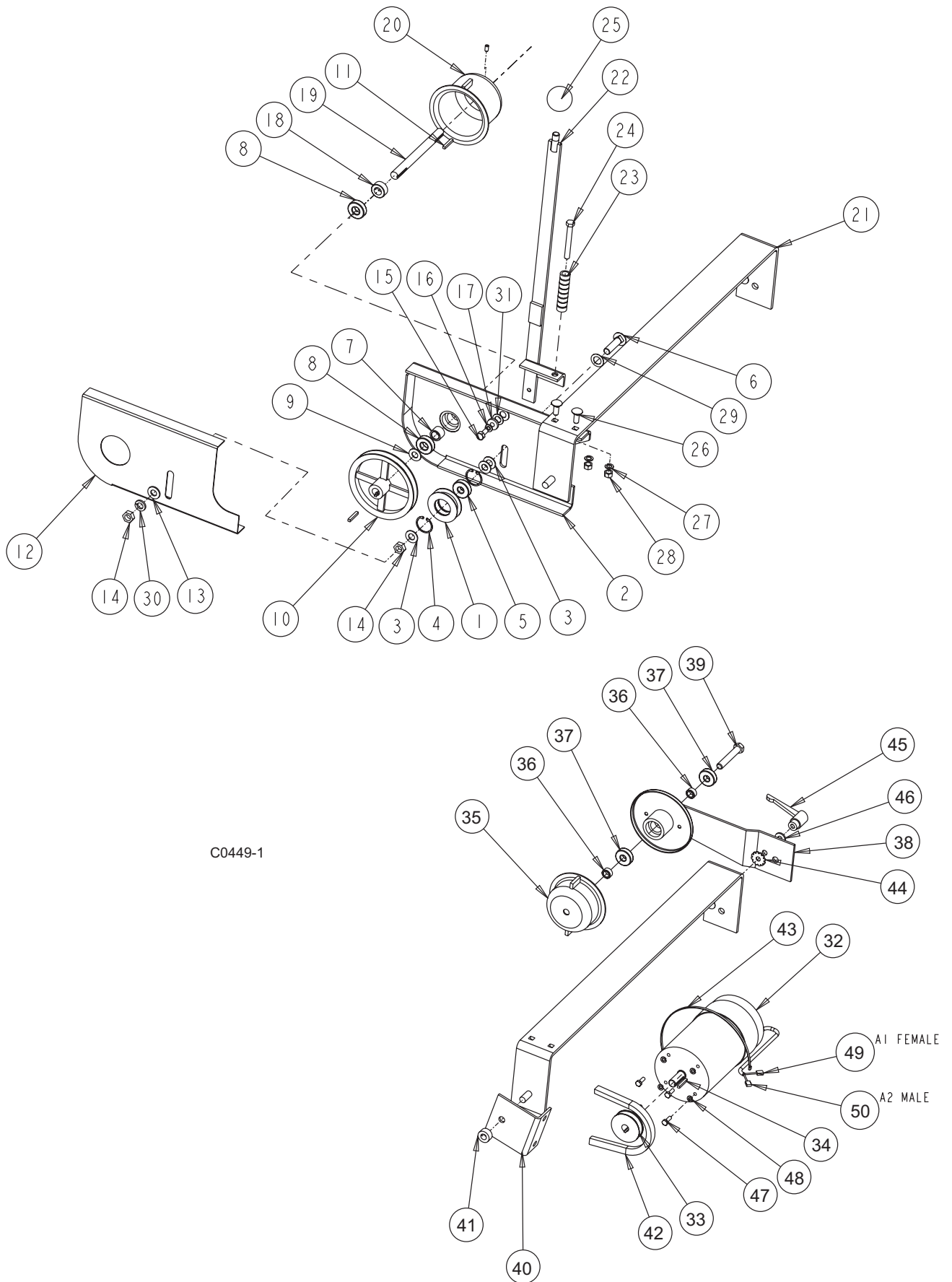

C0449-1

SIDE BROOMS AND DEFLECTOR- PARTS LIST

<u>KEY NO.</u>	<u>PART NUMBER</u>	<u>DESCRIPTION</u>	<u>QTY</u>
1	0885-082	Brush Drive Motor	2
	0875-134	Brushes for 0885-082	
2	8-03-04297	Motor Mounting Bracket	2
3	8-08-00769	Motor Mounting Bracket	1
4	7-25-06035	Flange, Side Broom	2
5	8-08-03215	Side Broom	2
6	8-08-00770	Motor Mounting Bracket	1
7	8-31-07012	Hanger, Side Broom	1
8	8-10-00036	Lift Cable	2
9	8-18-03024	Deflector	1
10	8-41-00049	Deflector Latch	1
11	2-00-04578	Wire Terminal (Male)	2
12	2-00-04626	Wire Terminal (Female)	2
13	2-00-00263	Set Screw, 1/4-20 x .25	4
14	2-00-04345	Tye-Wrap	4
15	8-79-00030	Strap	1
16	8-90-07431	Wire, Drive Motor	1
17	8-06-05004	Stand Off	2
18	2-00-04203	Boot	2
19	0895-107	Wire Harness	Ref.
20	2-00-04937	Tye- Wrap	1
21	8-21-04054	Edging	1

HARDWARE USED:

H7	2-00-00056	Screw #10-24 x .750 RHM	2
H10	2-00-00519	Lock Washer #10 Med. HS	2
H11	2-00-00605	Nut Hex MS #10-24 x .375 x .125	2
H12	2-00-01246	Nut,Hex Fiber Insert #10-24	1
H15	2-00-00221	Screw, 1/4-20 x.750 HHC	11
H17	2-00-00205	Screw, 1/4-20 x.75 HHC	5
H22	2-00-02589	Screw, 1/4-20 x 2.000 HHC	6
H25	2-00-00594	Nut Hex 1/4-20	8
H26	2-00-00641	Nut, 1/4-20 Insert Fiber	8
H27	2-00-03702	Flat Washer, .625 x .281 x .062	11
H38	2-00-00225	Screw, 5/16-18 x 1.50 HHC	1
H44	2-00-00530	Lock Washer, 5/16 HS Med.	2
H45	2-00-00585	Nut, Hex. 5/16-18 x .500 x .265	2
H48	2-00-00233	Screw, 3/8-16 x 1.000 HHC	2
H52	2-00-00402	Washer	1
H53	2-00-02310	Lock Washer, Helical Spring 3/8 Med.	2
H57	2-00-00240	Screw, 1/2-13 x 1.250 HHC	2
H65	2-00-04936	Nut, 1/2-13 Fiber Lock	2
H72	2-00-00518	Lock Washer, Helical spring 1/4 Med.	14
H115	2-00-03063	Screw, #10-24 x .750 THM	1
H120	2-00-03829	Lock Washer, 3/8 "	1
H136	2-00-03940	Screw, #10-24 x .500 MMTF	2
H204	2-00-04873	Clamp	1

C-0457/0201

SIDE BROOMS AND DEFLECTOR- EXPLODED VIEW

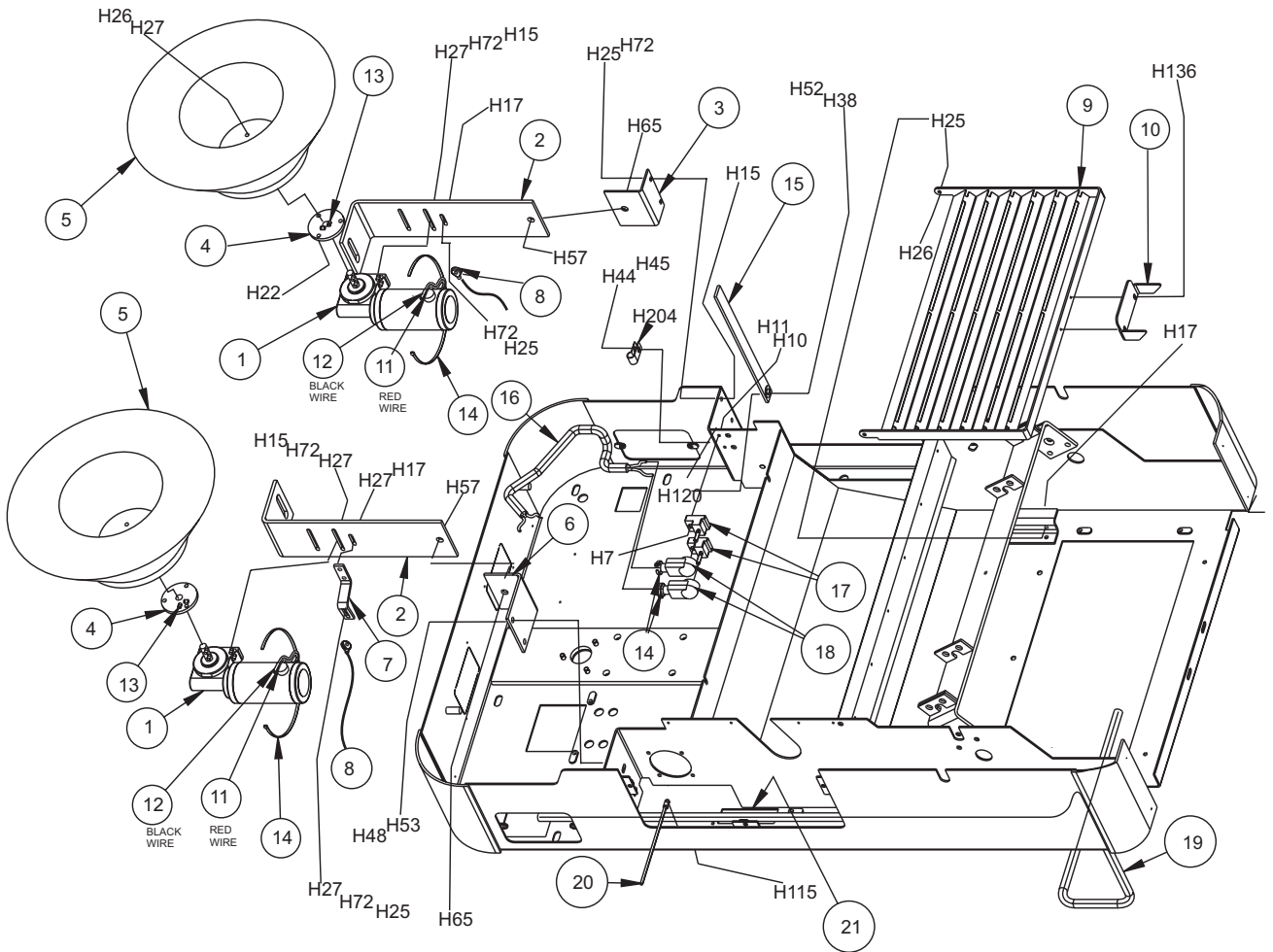

C0457/0201

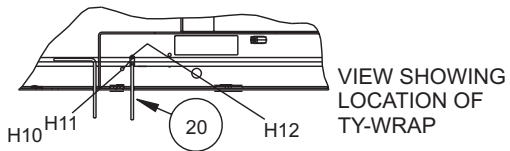

DOORS, FLAPS & SEALS - PARTS LIST

<u>KEY NO.</u>	<u>PART NUMBER</u>	<u>DESCRIPTION</u>	<u>QTY</u>
1	8-19-08056	Door, R.H.	1
2	8-13-07110	Clamp, R.H. Front	1
3	8-13-07108	Clamp, R.H. Rear	1
4	8-25-08191	Flap, Right Side	1
5	8-68-05072	Seal, Side Hopper	2
6	8-25-08190	Flap, Rear Outer	1
7	8-13-07107	Clamp	4
8	8-29-00226	Seal, Center Hopper	1
9	8-25-08186	Flap, Rear Inner	1
10	8-31-07010	Hanger, Rear Flap	1
11	8-29-00224	Seal, Door Upper	1
12	8-29-00225	Seal, Door Lower	2
13	8-19-08057	Door, L.H.	1
14	8-25-08187	Flap, L.H. Door	1
15	8-41-00044	Latch	1
16	8-13-07109	Clamp, L.H. Door	1
17	8-32-00044	Hinge	1
18			
19	8-25-08188	Flap, Front Outer	1
20	8-31-07011	Hanger, Front Flap	1
21	8-25-08189	Flap	1
22	8-27-07110	Frame, 114RS	1
23	8-19-08055	Door Side Broom	2
24	2-00-03038	Screw, 1/4-20 x .500	2
25	2-00-04190	Carriage Bolt, 1/4-20 x .625	3

HARDWARE USED:

H15	2-00-00221	Screw, 1/4-20 x .750 HHC	7
H25	2-00-00594	Nut, Hex 1/4-20 x .437 x .218	6
H72	2-00-00518	Lock Washer, Helical Spring 1/4 Med.	13
H136	2-00-03940	Screw, #10-24 x .500 MMTF	32

C-0456/9812

DOORS, FLAPS & SEALS - EXPLODED VIEW

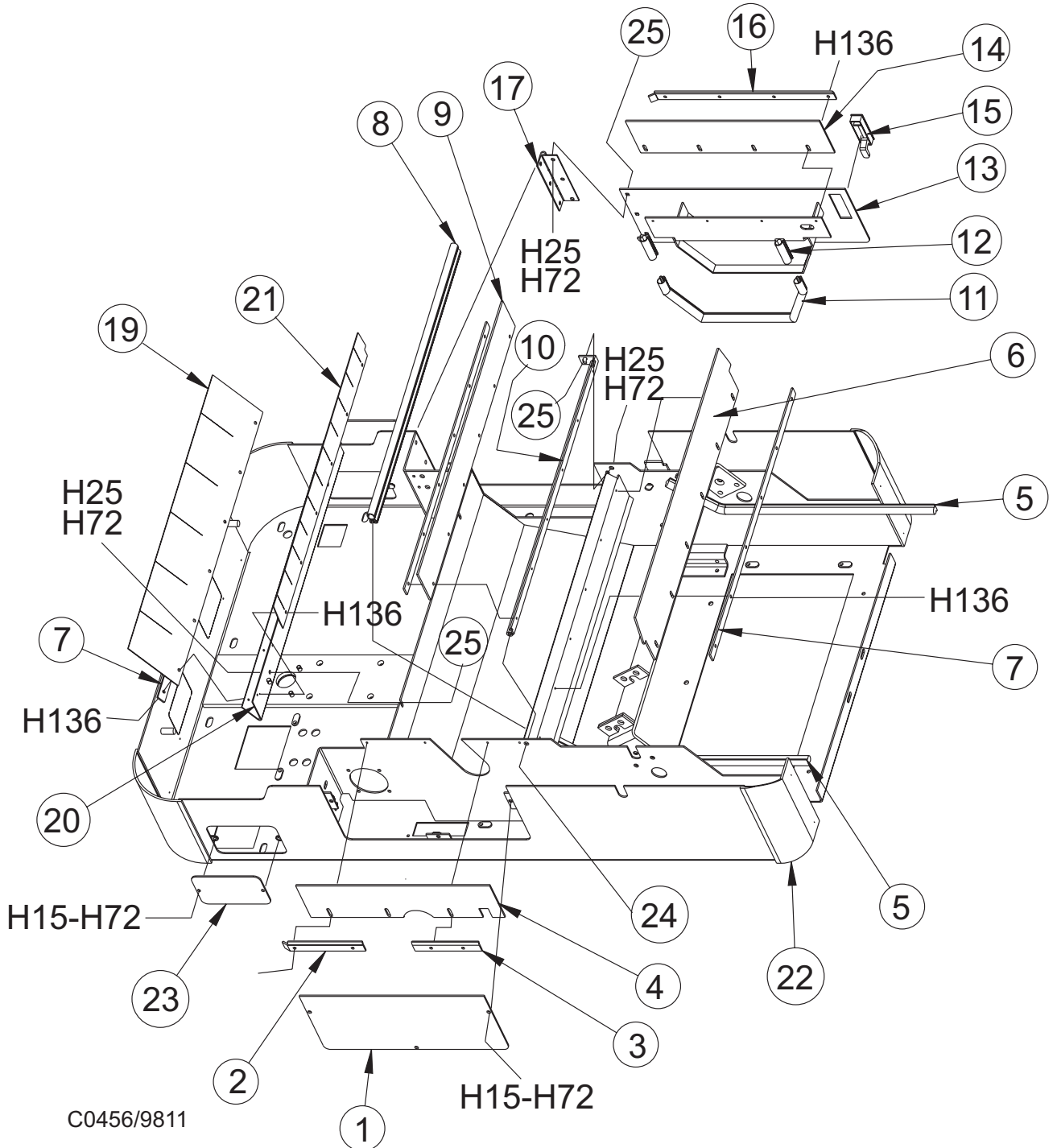

SIDE COVER & BATTERY PAN

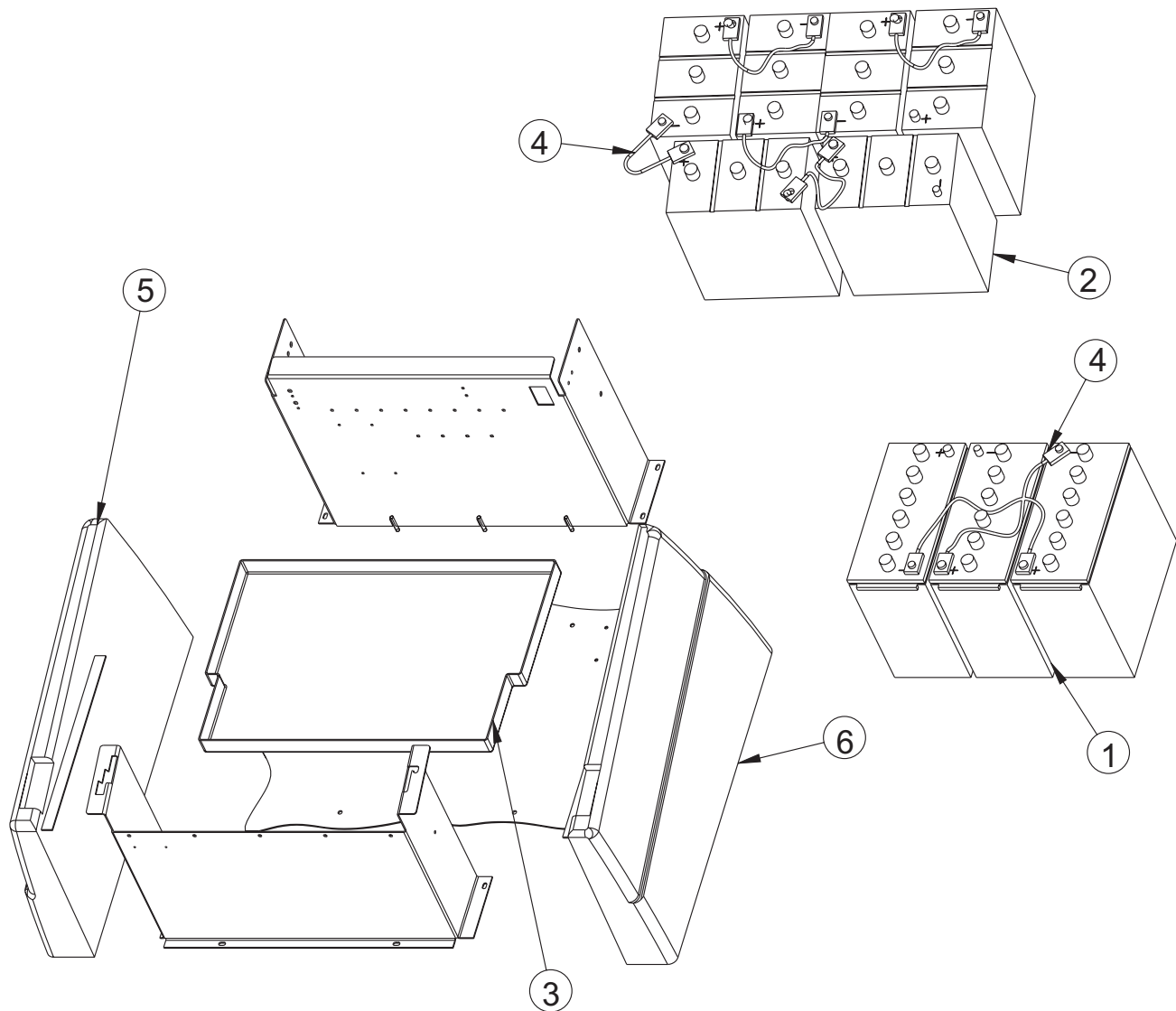

C455a/9811

<u>KEY NO.</u>	<u>PART NUMBER</u>	<u>DESCRIPTION</u>	<u>QTY</u>
1	0875-105	Battery (12 volt)	3
2	0875-103	Battery (6 volt)	6
3	8-51-05016	Battery Pan	1
4	7-90-07286	Wire - Battery (12 volt)	2
4	7-90-07286	Wire - Battery (6 volt)	5
5	8-16-07413	Side Cover	1
6	8-16-07414	Side Cover	1

C-0455a/9811

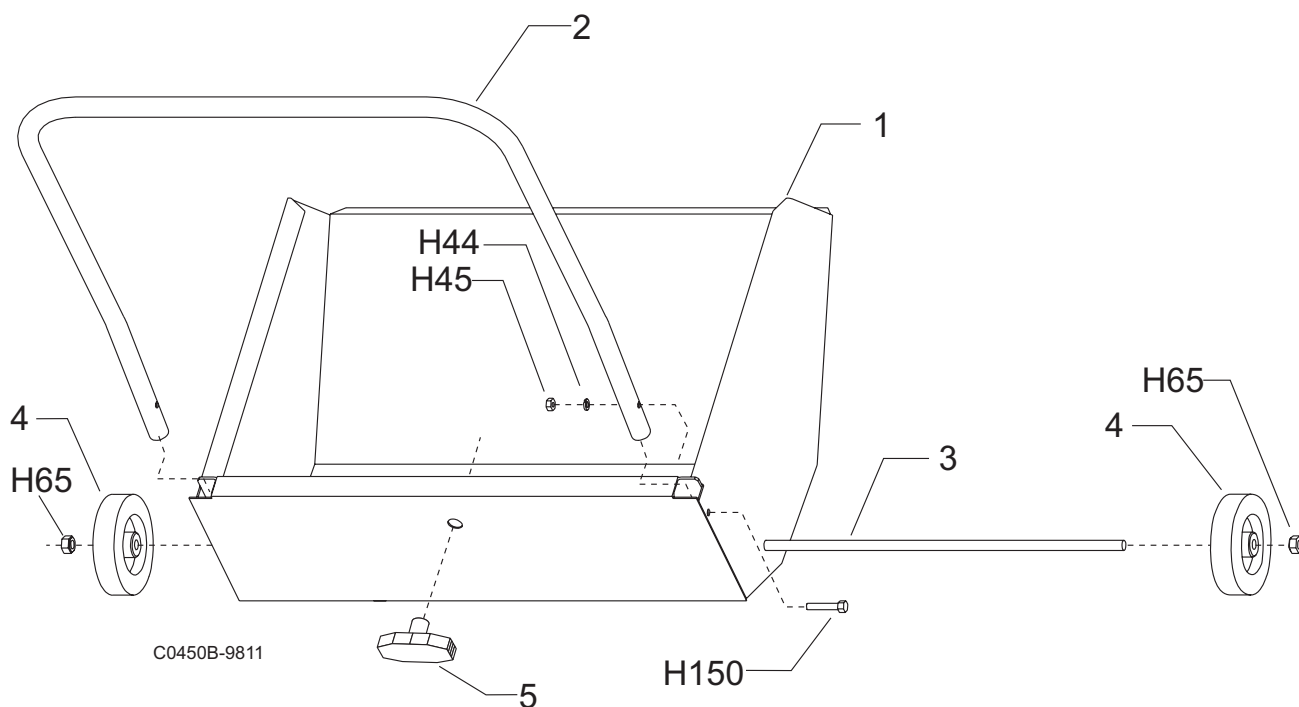

<u>KEY NO.</u>	<u>PART NUMBER</u>	<u>DESCRIPTION</u>	<u>QTY</u>
1	8-32-06101	Hopper	1
2	8-31-06082	Handle	1
3	8-70-05290	Axle	1
4	8-89-08066	Wheel	2
5	8-41-00060	Latch	1

HARDWARE USED:

H45	2-00-00585	Nut, Hex. 5/16-18 x .500 x .265	2
H44	2-00-00530	Lock Washer, 5/16 HS Med.	2
H65	2-00-04936	Nut, 1/2-13 Fiber Lock	2
H150	2-00-00211	Screw, 5/16-18 x 1.750 HHC	2

C-0450/9812

FORWARD/REVERSE PEDAL - PARTS LIST

<u>KEY NO.</u>	<u>PART NUMBER</u>	<u>DESCRIPTION</u>	<u>QTY</u>
1	8-08-00764	Bracket, Pedal Mounting	1
2	8-55-00032	Pedal, Forward/Reverse	1
3	7-08-00592	Bracket, Pedal Mounting (Black)	2
4	8-16-00025	Centering Device	1
5	0875-113	Potentiometer	1
6	7-03-04137	Potentiometer Lever Arm	1
7	8-14-01006	Clevis	2
8	8-42-05135	Interconnecting Rod	1
9	2-95-01999	Nut, 1/4-28	2
10	7-66-00147	Interconnecting Rod	1

HARDWARE USED:

H15	2-00-00221	Screw, 1/4-20 x .750 HHC	5
H25	2-00-00594	Nut, Hex 1/4-20 x .437 x .218	5
H27	2-00-03702	Washer, .625 x .281 x .062	2
H34	2-00-00208	Screw, 5/16-18 x .750 HHC	2
H40	2-00-01770	Bolt, Hex Head, 5/16 - 18 x 2.750	1
H44	2-00-00530	Lock Washer, 5/16 Med. HS	3
H45	2-00-00585	Nut Hex, 5/16-18 x.500 x.265	2
H52	2-00-00402	Washer, .750 x .390 x .093	2
H72	2-00-00518	Lock Washer, Helical Spring 1/4 Med.	5
H79	2-00-01676	Flat Washer, 1.062 x .265 x .062	1
H232	2-00-04909	Yoke Pin Assembly	1
H300	2-00-00767	Cotter Pin, .063 x.500	2

C-0453/9812

FORWARD/REVERSE PEDAL - EXPLODED VIEW

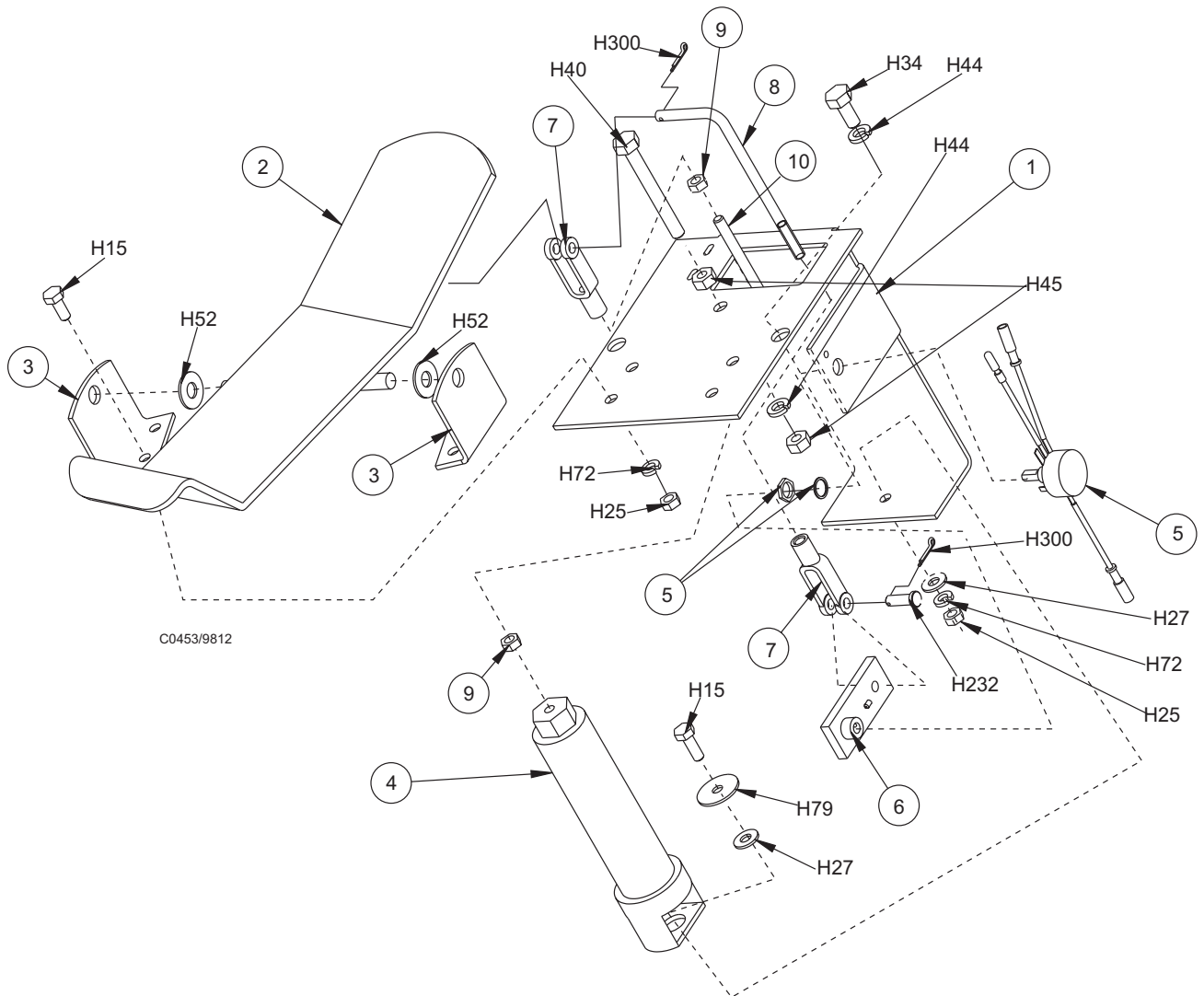

CONSOLE ASSEMBLY - PARTS LIST

<u>KEY NO.</u>	<u>PART NUMBER</u>	<u>DESCRIPTION</u>	<u>QTY</u>
1	8-33-05149	Console	1
2	8-52-00166	Instrument Panel (R.H.)	1
3	8-52-00165	Instrument Panel (L.H.)	1
4	8-41-05078	Lift Arm	1
5	7-31-06065	Cover	1
6	2-95-04689	Flat Washer	2
7	8-10-00036	Cable	2
8	7-60-00160	Pulley	1
9	7-09-01057	Spacer	1
10	0895-108	Wire Harness, Instrument Panel	1
11	7-13-07130	Bracket - Cable Clamp	1

HARDWARE USED:

H26	2-00-00641	Nut, 1/4-20 Insert Fiber	1
H38	2-00-00225	Screw, 5/16 - x 1.500 HHC	1
H43	2-00-00409	Flat Washer, .687 x .343 x .062	9
H44	2-00-00530	Lock Washer, 5/16 HS Med.	7
H46	2-00-00644	Nut, 3/8 - 16 Stop	2
H51	2-00-00216	Screw, 3/8 - 16 x 2.000 HHC	1
H52	2-00-00402	Washer, .750 x .390 x .093	2
H64	2-00-00596	Nut, Hex 1/2 - 13 x .750 x .437	1
H93	2-00-00222	Screw, 1/4-20 x 1.250 HHM	1
H95	2-00-03382	Spring Washer, .875 x .500 x .015	1
H126	2-00-03466	Screw, # 10-16 x .500 TF/RH	1
H149	2-00-01803	Washer Flat, 1.062 x .328 x .062	6
H150	2-00-00211	Screw, 5/16-18 x 1.750 HHC	1
H151	2-00-00213	Screw, 5/16-18 x .625 HHC	6
H244	2-00-05297	Nut, Insert Fiber .38 - 16 Heavy Nut	1

C-0460/9812

CONSOLE ASSEMBLY - EXPLODED VIEW

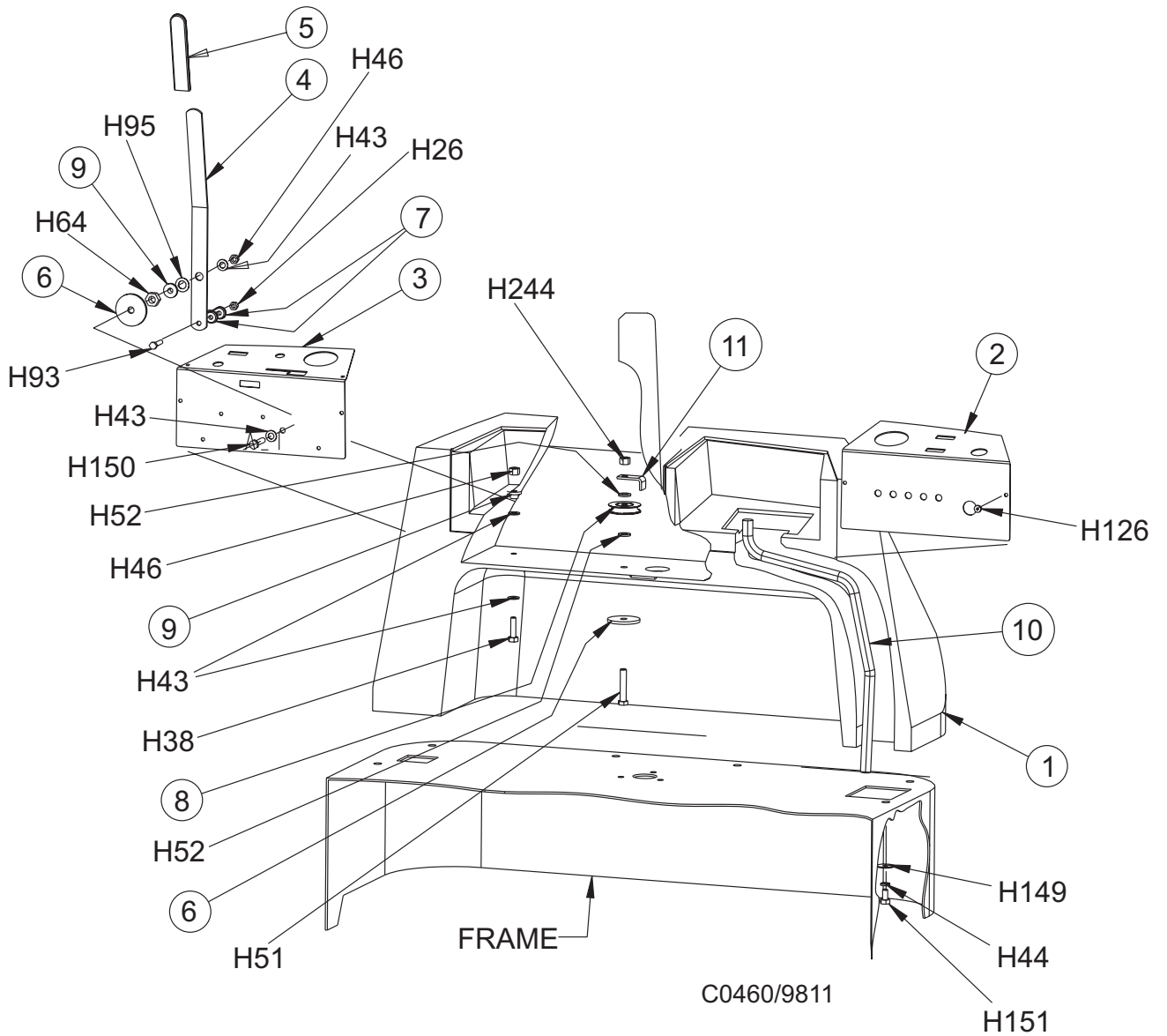

FILTER SYSTEM - PARTS LIST

<u>KEY NO.</u>	<u>PART NUMBER</u>	<u>DESCRIPTION</u>	<u>QTY</u>
1	8-24-04074-1	Filter	1
	8-24-04074-2	POLY Filter Option	
2	8-55-08114	Pivot Rod	1
3	7-58-05278	Plate, Shaker Motor	1
4	7-03-04135	Arm, Shaker	1
5	8-48-00019	Impellor Manifold	1
6	8-23-00013	Impellor	1
7	8-08-00796	Bracket, Impellor Motor and Guard	1
8	0882-062	Impellor Motor	1
9	8-16-07406	Shaker Motor Cover	1
10	0860-624	Filter Shaker Motor (36V)	1
11	8-89-04019	Filter Shaker Weight	1
12	8-80-05038	Rod, Threaded 5/16-18	4
13	2-00-05183	Terminals 1/4 FISO (Male)	2
14	2-00-03589	Collar	4
15	8-29-00229	Gasket	2
16	8-29-00228	Gasket	2
17			
18			
19	8-90-07430	Wire	1
20	8-23-03068	Nut - Tee	2

HARDWARE USED:

H15	2-00-00221	Screw, 1/4-20 x .750 HHC	4
H26	2-00-00641	Nut, 1/4-20 Insert Fiber	8
H27	2-00-03702	Washer, .625 x .281 x .063	2
H44	2-00-00530	Flat Washer, 5/16	3
H46	2-00-00644	Nut, 5/16-18 Insert Fiber	4
H72	2-00-00518	Lock Washer, Helical Spring ¼ Med.	4
H86	2-00-03575	Carriage Blt, 1/4-20 x .750	8
H87	2-00-00263	Set Screw, 1/4-20 x .250 HSKCP	2
H151	2-00-00213	Screw, 5/16-18 x .625 HHC	4
H287	2-00-00264	Set Screw, 1/4-20 x .313 HSKCP	1
H288	2-00-00668	Wing Nut, 5/16-18	2

C-0452/9811

FILTER SYSTEM - EXPLODED VIEW

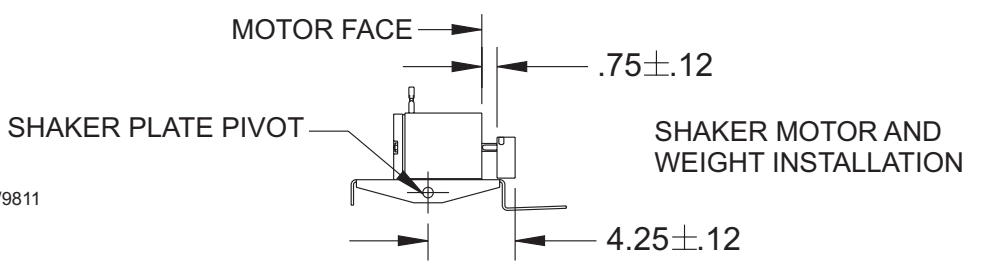
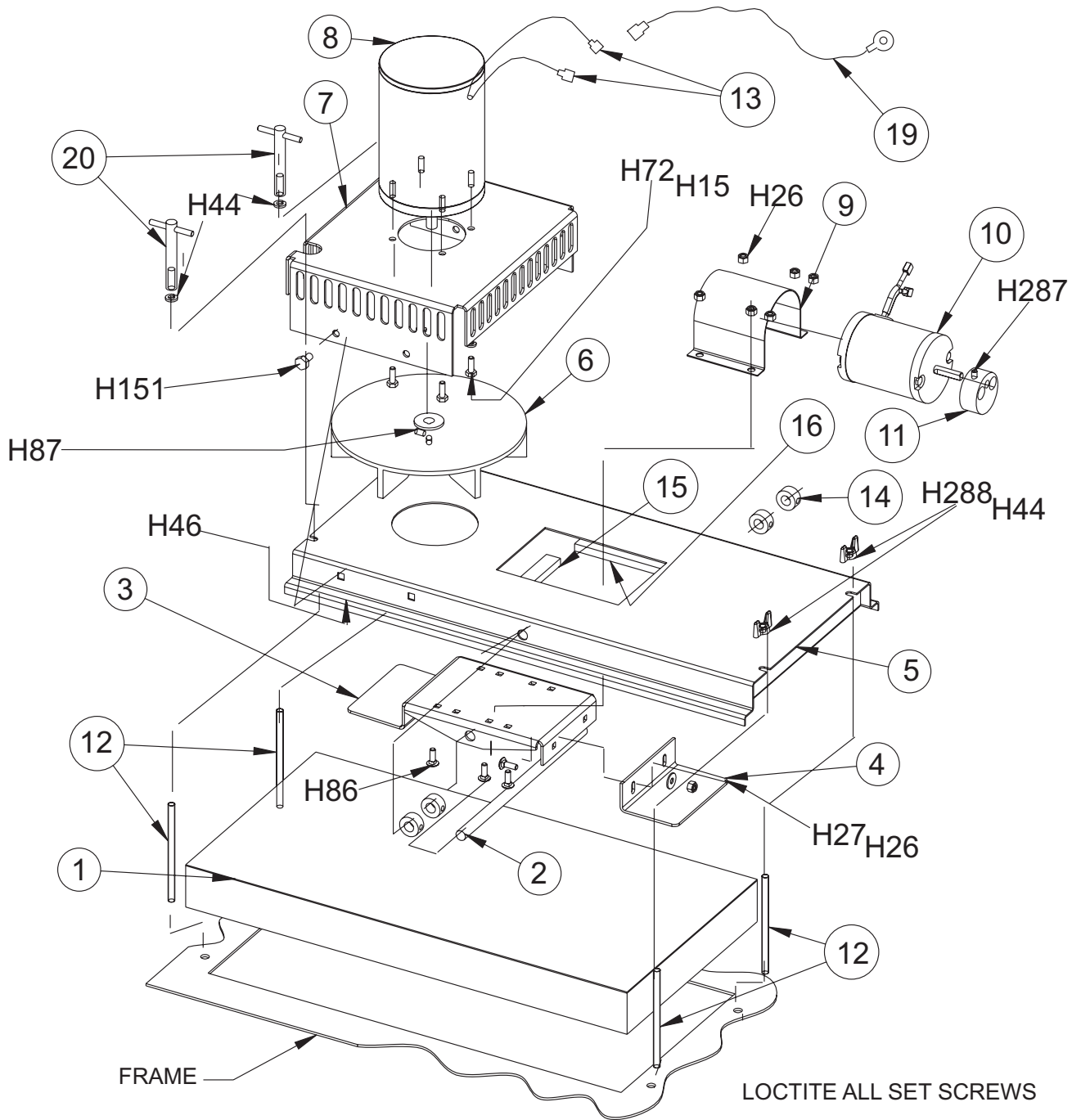

C0452/9811

DRIVE COMPARTMENT & SEAT - PARTS LIST

<u>KEY NO.</u>	<u>PART NUMBER</u>	<u>DESCRIPTION</u>	<u>QTY</u>
1	8-52-00161	Drive Compartment	1
2	8-32-00045	Hinge	1
3	8-52-00159	Seat Base	1
4	8-69-00022	Seat	1
5	7-72-05005	Slide Adjuster Kit	1
6			
7	7-03-04114	Bar, Seat Lock	1
8	7-50-05151	Seal	2
9	8-21-04050	Edging, Seat Panel	1
10	8-68-05072	Seal	1
11	7-82-00037	Switch, Broom	1
12	8-08-00763	Bracket, Broom Switch	1
13	8-50-00014	Serial Plate	
14			
15	2-00-04115	Rivet	2

HARDWARE USED:

H6	2-00-00049	Screw, #10-24 x .50 RHM	4
H34	2-00-00208	Screw, 5/16-18 x .750 HHC	4
H15	2-00-00221	Screw, 1/4 - 20 .750 HHC	9
H93	2-00-00222	Screw, 1/4 - 20 x 1.250 HHM	1
H43	2-00-00409	Flat Washer, .687 x .343 x .062	4
H9	2-00-00426	Flat Washer, .500 x .218 x .062	2
H72	2-00-00518	Lock Washer, Helical Spring 1/4 Med.	10
H10	2-00-00519	Lock Washer, #10 Med.	2
H44	2-00-00530	Lock Washer, 5/16 HS Med.	4
H25	2-00-00594	Nut, Hex 1/4-20 x .437 x .218	10
H11	2-00-00605	Nut, Hex #10-24 MS	2
H26	2-00-00641	Nut, 1/4-20 Insert Fiber	1
H46	2-00-00644	Nut Fiber Insert, 5/16 - 18	4
H12	2-00-01246	Nut Fiber Insert #10-24	2
H27	2-00-03702	Washer, .625 x .281 x .063	10

C-0454/0903

DRIVE COMPARTMENT & SEAT - EXPLODED VIEW

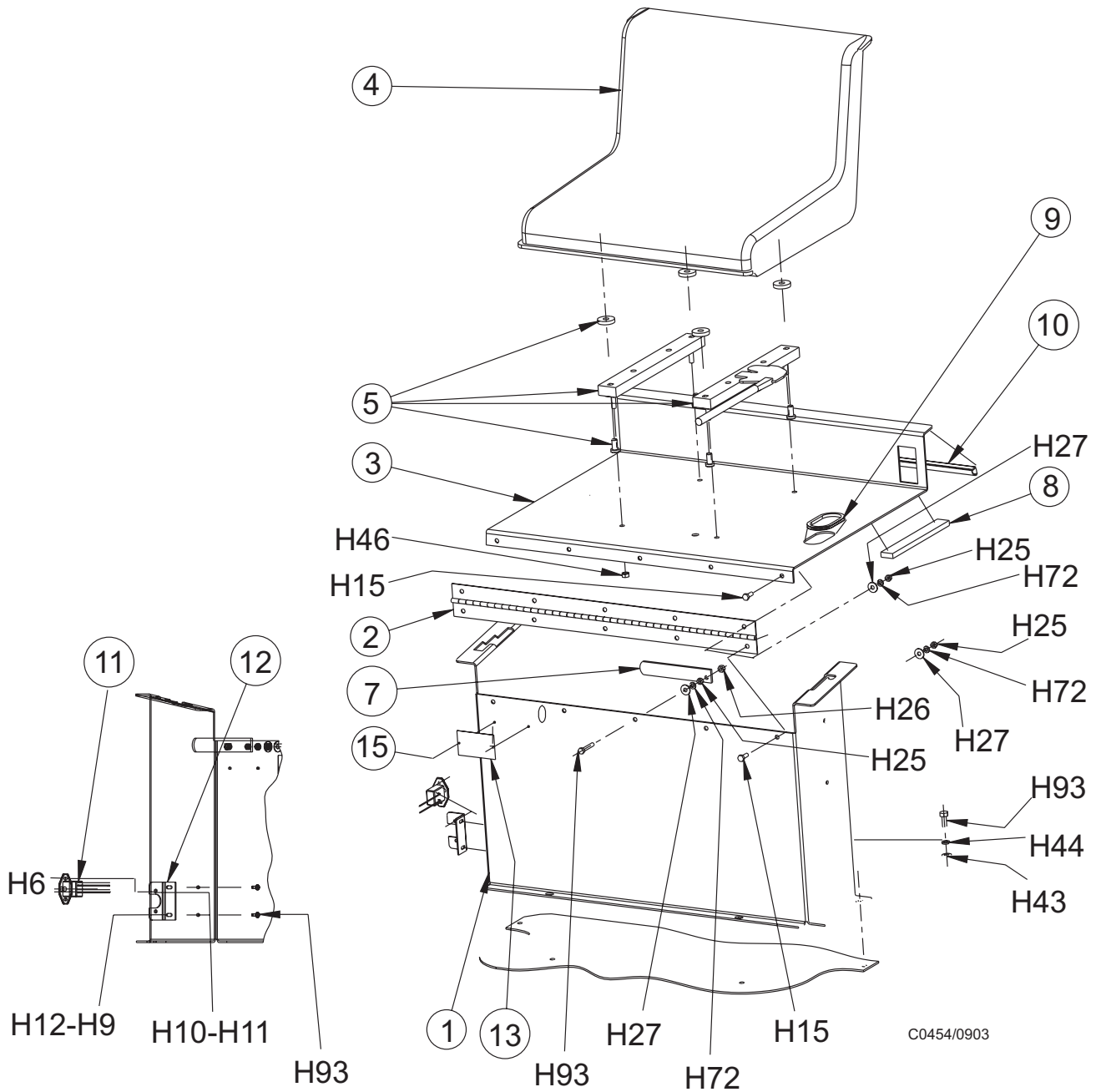

STEERING & DRIVE - PARTS LIST

<u>KEY NO.</u>	<u>PART NUMBER</u>	<u>DESCRIPTION</u>	<u>QTY</u>
1	0885-081	Wheel and Drive Motor Gray Rubber Tire ONLY: 2-60-02284	1
2	8-58-05272	Plate, Drive Wheel Mounting	1
3	8-58-05268	Bracket, Drive Wheel Mounting	1
4	8-57-05022	Sproket	Ref
5*~	7-57-05071	Pivot Caster	1
6	7-25-06031	Flange, Steering Mount	2
7	7-70-05158	Steering Shaft	1
8	7-37-00001	Universal Joint	1
9	8-70-05292	Shaft, Steering Wheel	1
10	7-89-08083	Steering Wheel	1
11	7-13-05065	Steering Chain	1
12	2-00-05159	Bearing, 1.000	2
13	8-81-00167	Support, Wheel Guard	2
14	8-30-05160	Wheel Guard	1
15	8-25-08192	Flap	1
16	8-32-09008	Horn	1
17	8-31-07013	Hanger	1
18	8-90-07431	Wire assy.	Ref.
19	2-00-04203	Boots, Terminal	2
20	2-00-00205	Screw, 1/4-20 x1.00	1
21	2-00-00203	Screw, 1/4-20 x 1.750 HHC	2
22	2-00-00594	Nut, Hex 1/4 - 20 x .437 x .218	1
23	2-00-00641	Nut, 1/4-20 Insert Fiber	2
24	2-00-00225	Screw, 5/16-18 x 1.50 HHC	1
25	2-00-00409	Flat Washer, .687 x .344 x .062	3
26	2-00-00530	Lock Washer, 5/16 HS Med.	7
27	2-00-00402	Washer, .750 x .390 x .093	1
28	2-00-02310	Lock Washer, Helical Spring 3/8 Med.	4
29	2-00-02360	Nut, 3/8-16 Hex	3
30	2-00-00518	Lock Washer, Helical Spring	1
31	2-00-01676	Flat Washer, .750 x .265 x .062	1
32	2-00-00228	Screw, 5/16-18 x 2.250 HHC	3
33	2-00-05005	Screw, #10 x 1.5 30 mm HHC	4
34	2-00-02311	Lock Washer, 7/16 Split, Cadmium Plated	4
35	2-00-03940	Screw, #10-24 x .500 MMTF	9
36	2-00-00206	Screw, 5/16-18 x 1.00	3
37	2-00-04873	Clamp	1
38	2-00-00466	Flat Washer, # 10 SS	9
39	2-00-03750	Carriage Bolt, 3/8-16 x 1.500	4
40	2-00-00868	Roll Pin	1
41	2-00-03266	Washer	4
42	2-00-05297	Nut, 3/8-16 Stop	4
43	2-00-04625	Screw, .375-24 x .75	4

80605/4-05

*SERVICE PART NUMBER IS 7-57-05071-1 ; TO BE ASSEMBLED AS SHOWN WITH DOUBLE HOLE TOWARDS FRONT OF MACHINE.

~INDIVIDUAL COMPONENT PARTS AVAILABLE AS SERVICE ITEMS INCLUDE:

7-57-05032	CASTER, PIVOT	(1)
8-57-05022	WELDMENT-PIVOT, STEERING	(1)
7-57-05032-3	PIVOT	(1)
2-00-05120	LOCKNUT, FIBER INSERT	(1)
2-00-05951	BOLT, BEARING ASSY.	(1)
2-00-06530**	BALL BEARINGS (1/2" DIA.)	(18)
2-00-06531**	BALL BEARINGS (3/8" DIA.)	(12)

**SERVICE KIT FOR ALL BALL BEARINGS IS P/N 0780-655

STEERING & DRIVE - EXPLODED VIEW

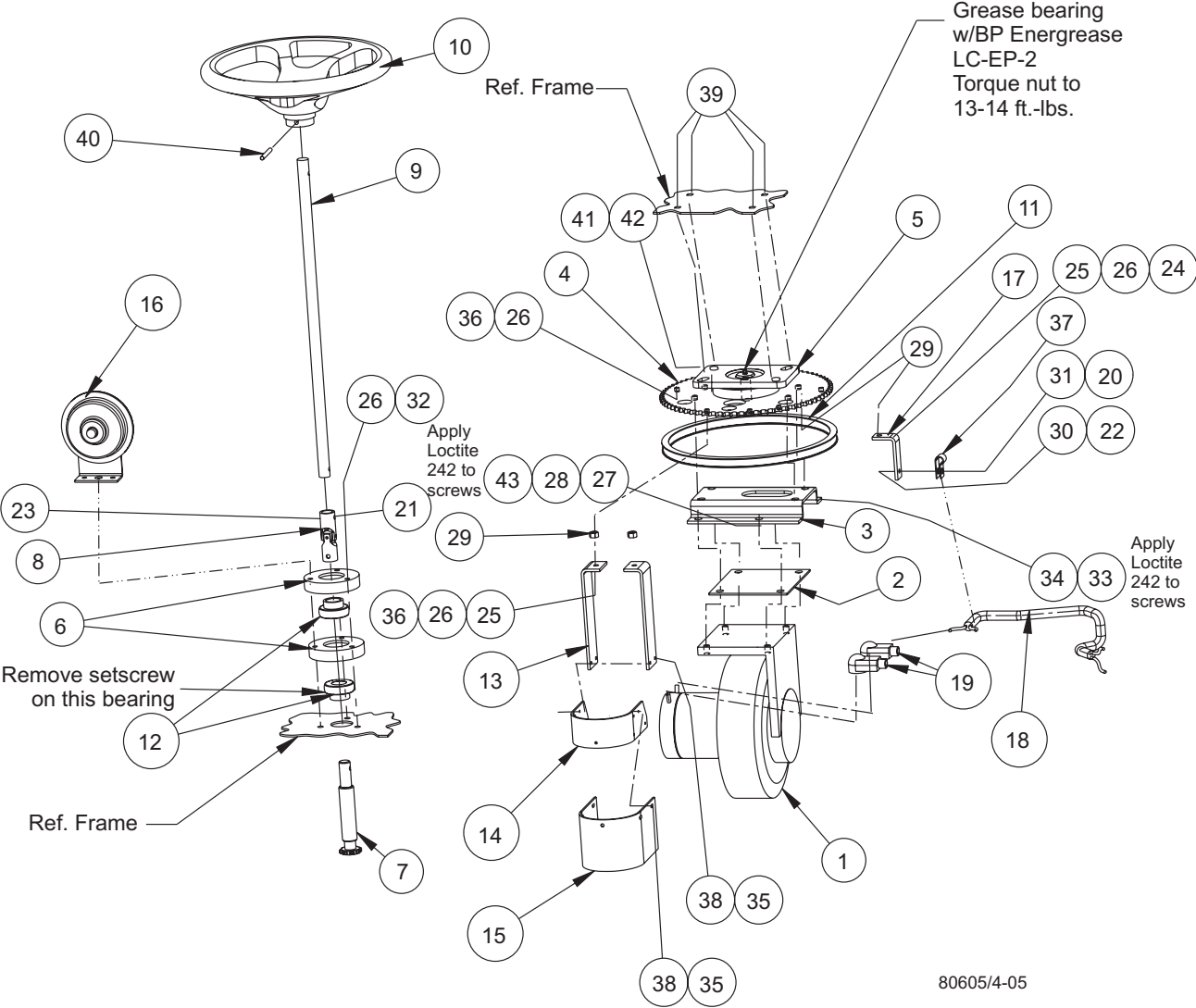

WHEEL LOCK - PARTS LIST

<u>KEY NO.</u>	<u>PART NUMBER</u>	<u>DESCRIPTION</u>	<u>QTY</u>
1	8-55-08130	Wheel Lock Rod	2
2	8-08-00771	Bracket	1
3	8-10-00035	Cable	1
4	7-76-00102	Spring	2
5	8-03-09024	Axle	2
6	8-75-01196	Spacer	2
7	8-33-09087	Hub Assembly	2
8	2-95-04689	Flat Washer	2
9	0797-041	Wheel Assembly (Ultraseal)	2
10	7-09-01057	Bushing	2
11	8-41-05080	Lever Wheel Lock	1
12	7-39-00017	Knob	1
13	2-00-05394	Clamp	2
14	2-00-05226	Bearing	4
15	2-00-05024	Washer	4
16	8-25-06011	Flange Rim	2

HARDWARE USED:

H20	2-00-00203	Screw, 1/4-20 x 1.750 HHC	1
H17	2-00-00205	Screw, 1/4-20 x 1.00	2
H34	2-00-00208	Screw, 5/16-18 x 1.25 HHC	10
H38	2-00-00225	Screw, 5/16-18 x 1.50 HHC	1
H48	2-00-00233	Screw, 3/8-16 x 1.000 HHC	2
H43	2-00-00409	Washer .687 x .343 x .062	1
H72	2-00-00518	Lock Washer 1/4 Med. Helical Spring	1
H44	2-00-00530	Lock Washer, 5/16 HS Med.	8
H25	2-00-00594	Nut Hex, 1/4-20 x .437 x .218	2
H26	2-00-00641	Nut, 1/4-20 Insert Fiber	5
H46	2-00-00644	Nut Hex 5/16-18 Fiber Insert	1
H53	2-00-02310	Lock Washer, 3/8 HS Med.	2
H282	2-00-02562	Fitting	2
H95	2-00-03382	Spring Washer, .875 x .500 x .015	1
H27	2-00-03702	Washer, .625 x .281 x .063	2
H283	2-00-03842	Roll Pin, 1/4 x 1.000 LG.	1
H284	2-00-04845	Screw, 3/8-16 x 1.00 FHSC	2
H285	2-00-05135	Screw, 1/4-20 x 1.50 HHC	1
H286	2-00-05383	Washer	2

C-0447/9811

WHEEL LOCK - EXPLODED VIEW

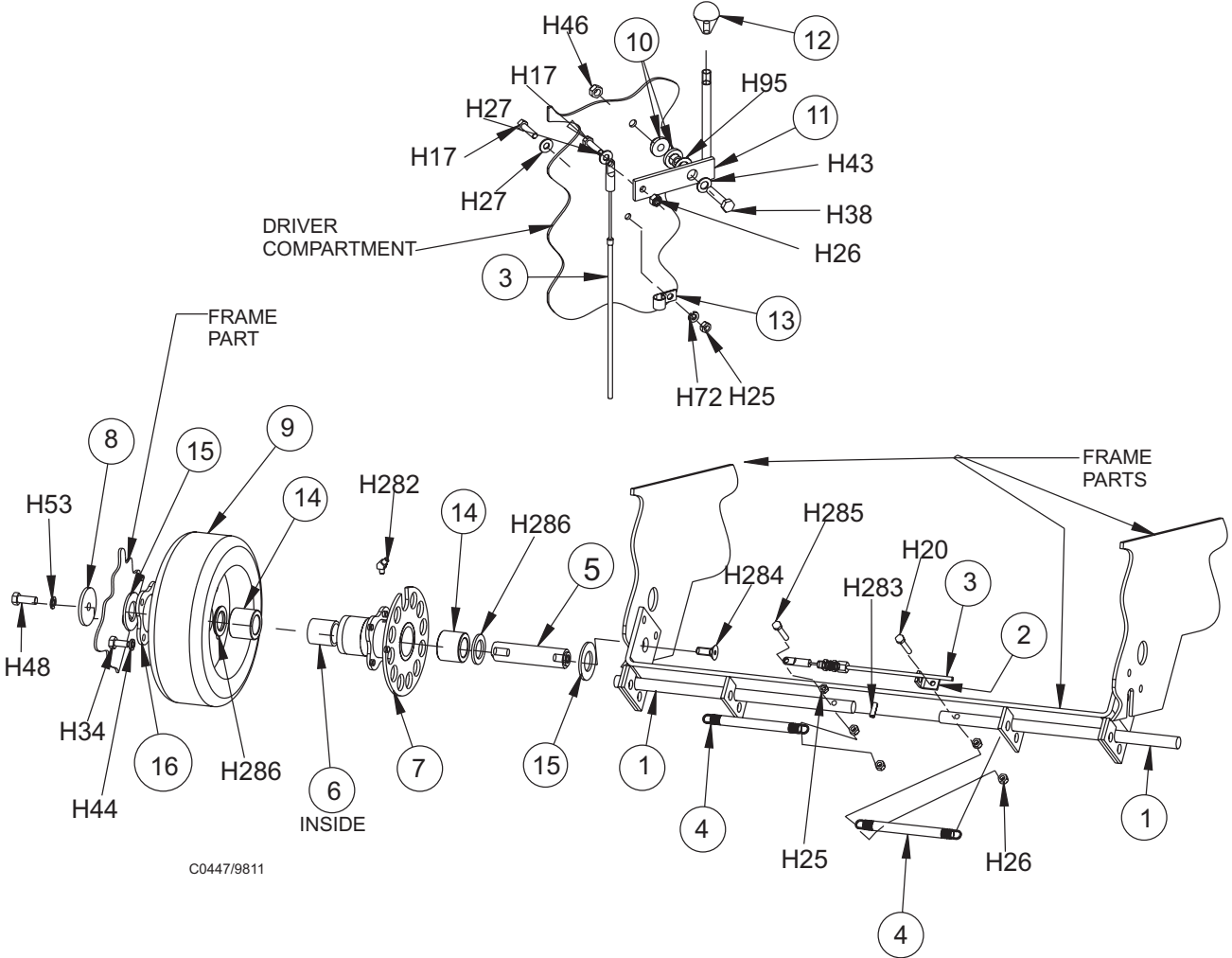

C0447/9811

POWER PANEL - PARTS LIST

<u>KEY NO.</u>	<u>PART NUMBER</u>	<u>DESCRIPTION</u>	<u>QTY</u>
1	8-52-00164	Panel	1
2	8-52-00160	Cover	1
3	0875-101	Power Cable	1
4	8-06-05004	standoff	2
5	7-64-00025	Circuit Breaker (25 amp)	1
6	7-64-00022	Circuit Breaker (20 amp)	1
7	0782-127	Controller	1
8	2-00-04825	Solenoids	4
9	0775-159	Diode Assembly	4
10	8-90-07429	Diode Assembly	1
11			
12	7-09-01046	Spacers	2
13	7-28-00001	Circuit Breaker (35 amp)	1
14	8-11-00044	Boot, CB	2
15	8-11-00051	Boot, CB	2
16	2-00-04952	Boot, Red	1
17	0895-107	Wire - Harness	1
18	8-79-00098	Bracket - Handle	1
19	8-31-06078	Handle	1

HARDWARE USED:

H8	2-00-00039	Screw, 10-24 x 1.000 RHM	2
H6	2-00-00049	Screw, # 10-24 x .500 RHM	4
H34	2-00-00208	Screw, 5/16-18 x .750 HHC	4
H15	2-00-00221	Screw, 1/4-20 x .750 HHC	10
H43	2-00-00409	Washer, .687 x .343 x .062	7
H9	2-00-00426	Flat Washer, .500 x .219 x .063	2
H72	2-00-00518	Lock Washer, Helical Spring	8
H10	2-00-00519	Lock Washer, # 10 Med HS	6
H44	2-00-00530	Lock Washer, 5/16 HS Med.	7
H45	2-00-00585	Nut, Hex. 5/16-18 x .500 x .265	3
H165	2-00-00589	Nut, Hex Jam 1/4-20 x .437 x .156	2
H25	2-00-00594	Nut, Hex 1/4-20 x .437 x .218	8
H11	2-00-00605	Nut, Hex MS # 10-24 x .375 x .125	4
H26	2-00-00641	Nut, 1/4-20 Insert Fiber	2
H12	2-00-01246	Nut, Hex Fiber Insert #10-24	2
H233	2-00-02638	Screw, 1/4-20 x 3.000 HHC	2
H27	2-00-03702	Washer, .625 x .281 x .0631	8

C0451/9811

POWER PANEL - EXPLODED VIEW

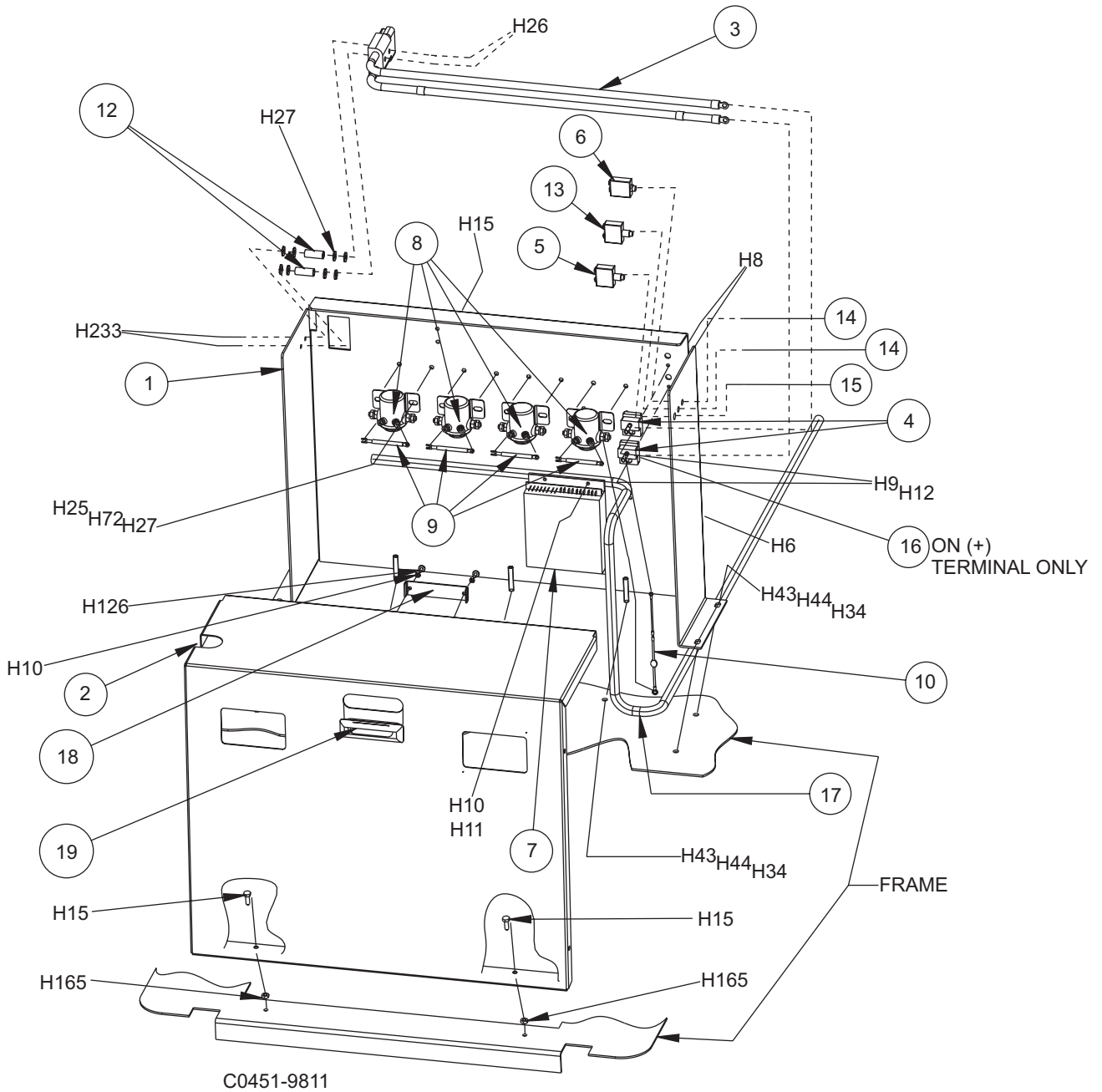

INSTRUMENT PANEL - PARTS LIST

<u>KEY NO.</u>	<u>PART NUMBER</u>	<u>DESCRIPTION</u>	<u>QTY</u>
1	8-48-05023	Hour Meter	1
2	8-82-00045	Momentary Switch	1
3	2-00-04514	Plug, Hole	1
4	8-82-00030	Switch	1
5	8-18-00389	Decal, Instrument Panel	1
6	7-48-05024	Battery Condition Meter	1
7	8-82-00044	Switch	2
8	8-64-00007	Circuit Breaker, 10 amp	4
9	8-18-00388	Decal, Instrument Panel	1
10	8-82-00041	Switch	1
11	8-11-00044	Boot	4
12	2-00-04757	Plug, Hole	4

Ignition Key: 2-60-02272

C-0463/9811

INSTRUMENT PANEL - EXPLODED VIEW

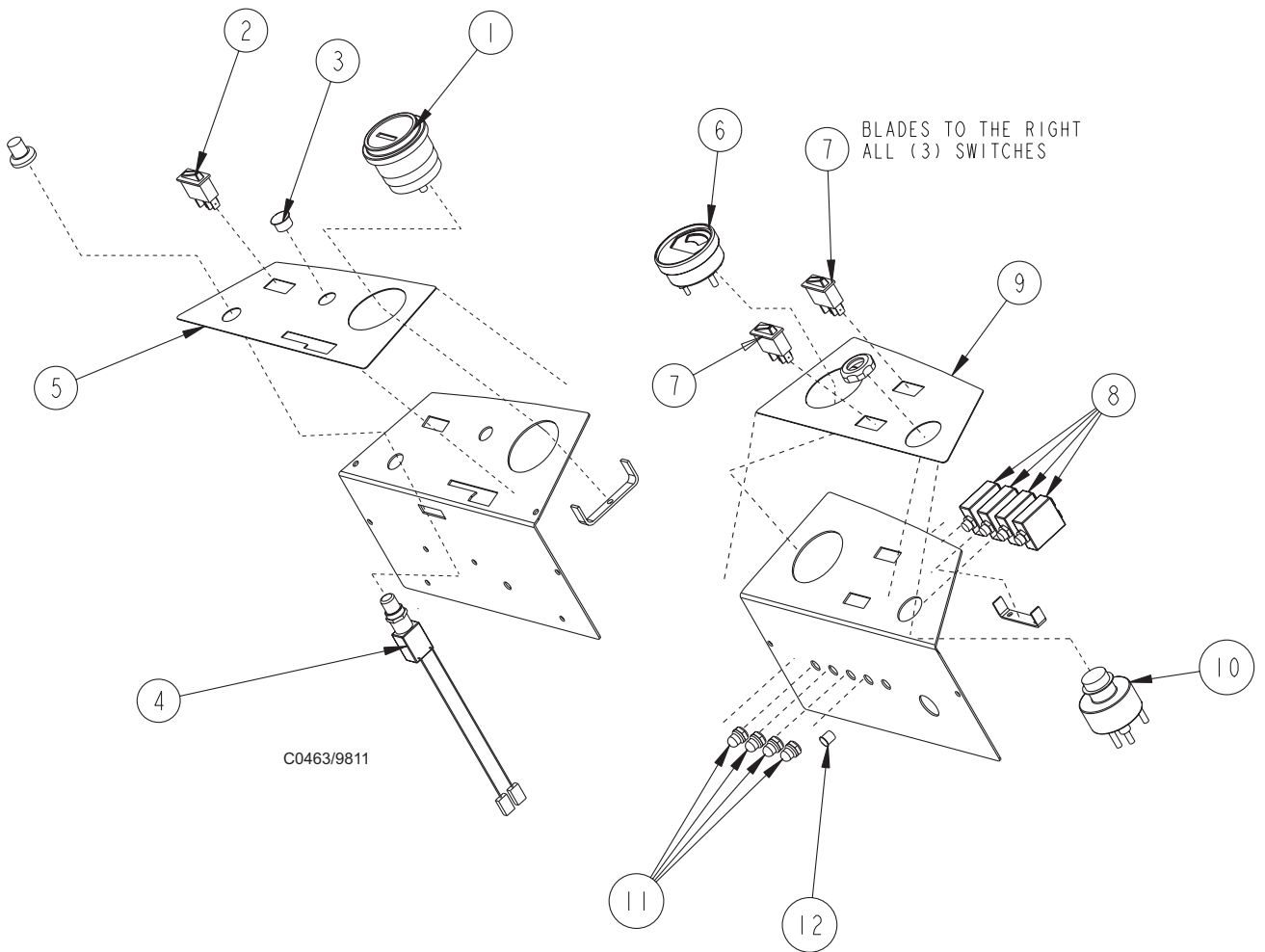

DECALS - PARTS LIST

<u>KEY NO.</u>	<u>PART NUMBER</u>	<u>DESCRIPTION</u>	<u>QTY</u>
1	8-18-00495	Parking Brake	1
2	8-18-00508	Circuit Breaker Panel	1
3	8-18-00510	Left Side Dash	1
4	8-18-00494	Main Broom	1
5	8-18-00511	Right Side Dash	1
6<*	REF	Battery Charging Warning	1
7	8-18-00490	Bi-Directional Pedal (horizontal)	1
8~	8-18-00487	Blank Square - Option Cover	1
9<	REF	Cover/Hopper Could Close	1
10<*	REF	Do Not Use with Flammables	1
11<*	REF	Electrical Hazard	1
12<	REF	Patent/Patents Pending	1
13<	REF	Turn Off - Lock Wheel	1
14<*	REF	Attention! Leave Battery Connected	1
15<	REF	Pinch Point - Stay Clear	1
16	8-18-00531	114RS	1
17	8-18-00549	A-L Technology (small) - Export Only	1
18	8-18-00524	American-Lincoln (small)	1
	8-18-00528	Alto (Large) - Export Only	1
19	8-18-00549	A-L Technology (small) - Export Only	1
20	REF	Serial Plate	1
21	8-50-05055	Non-Skid (Frame Edge)	2
22	8-50-05055	Non-Skid (Foward/Reverse)	1
23	2-00-04115	Rivets	2

<NO-TEXT warning decals & English TEXT warning decals included in Kit 0760-867

*ALL WARNING/SAFETY DECALS WITH TEXT SOLD IN A KIT BY LANGUAGE:

DANISH	0760-850	ITALIAN	0760-851
DUTCH	0760-849	FRENCH	0760-847
NORWEGIAN	0760-852	SPANISH	0760-846
SWEDISH	0760-853	PORTUGUESE	0760-854
GERMAN	0760-848		

~Can be ordered separately but is also included in 0760-867

C0476a/9-04

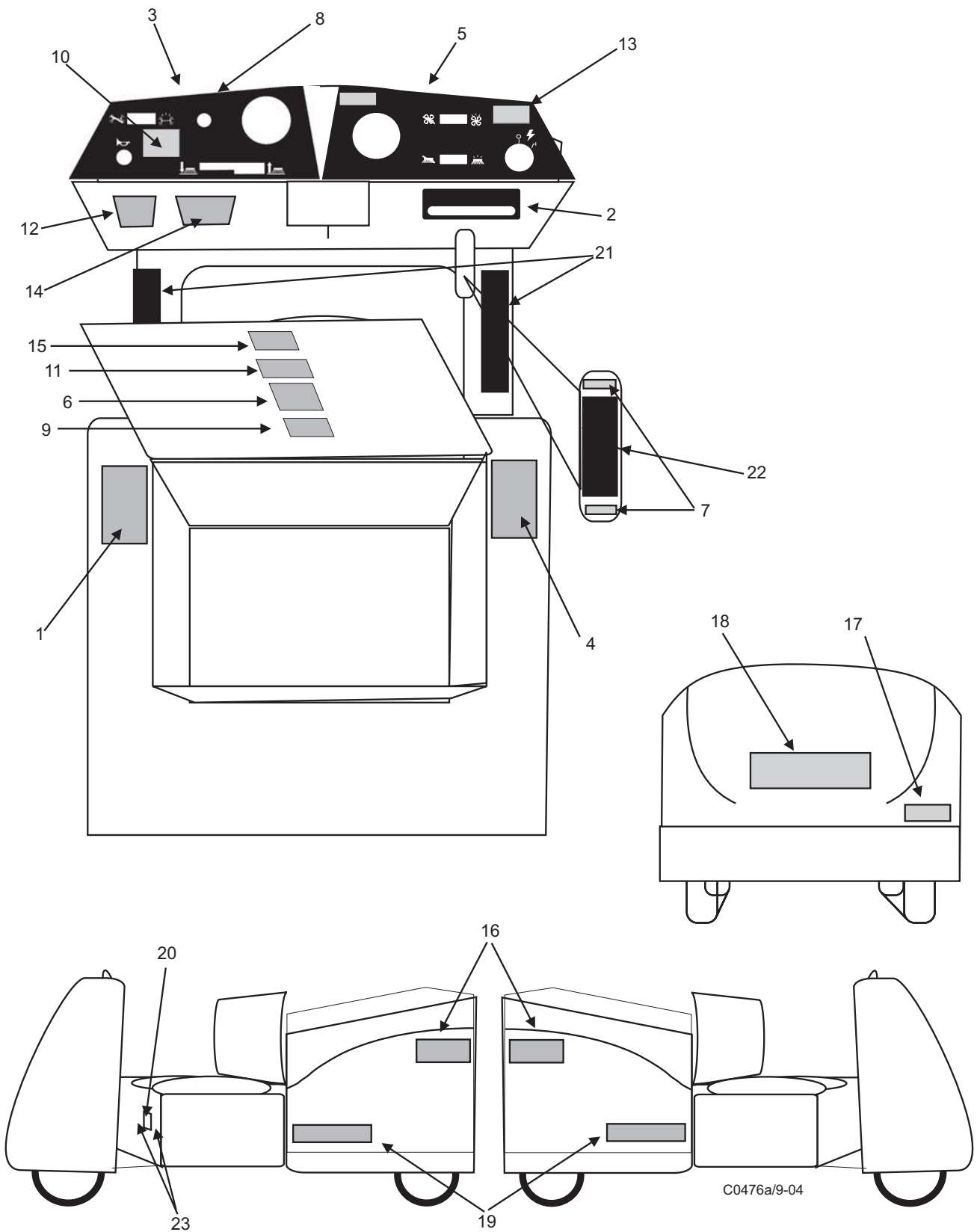

NOTES

TABLE OF CONTENTS - CHAPTER 3

Back-up Alarm	3-2
Battery Option	3-4
Broom Option	3-5
Head & Taillight Option	3-6
Overhead Guard Option	3-7
Amber Strobe Light Option	3-8
Strobe Light Option For Overhead Guard	3-9
Low Battery Shutdown Option	3-10
Emergency Stop Option	3-11
Vac Wand Option	3-12
Seat Safety Switch Option	3-14
Drive motor Service Parts	3-16
Spare Parts List	3-17
Index	3-18
Warranty	3-20

BACK-UP ALARM - PARTS LIST

OPTION 0880-580

<u>KEY NO.</u>	<u>PART NUMBER</u>	<u>DESCRIPTION</u>	<u>QTY</u>
1	8-75-01120	Spacer	2
2	7-82-00023	Switch	1
3	8-32-09009	Back-Up Alarm	1
4	8-64-00007	Circuit Breaker, 10 amp	1
5	8-11-00044	Boot	1
6	2-00-03418	Terminal	1
7	2-00-04479	Connector, 3-Way	1
8	3-61-00193	Wire, 16 ga. Red	6'
9	2-00-04626	Terminal, Female Bullet	2
10	2-00-04578	Terminal, Male Bullet	2
11	3-61-00189	Wire, 16 ga. Black	8'
12	2-00-04282	Terminal Ring	1
13	2-00-04345	Tye Raps	10
14	2-00-04742	Terminal Ring	2
15	2-00-00221	Screw, 1/4-20 x .750 HHC	2
16	2-00-00594	Nut, Hex 1/4-20 x .437 x .218	2
17	2-00-01490	Screw, 1/4-20 x .875 HHC	2
18	2-00-03702	Washer, .625 x .281 x .063	2
19	2-00-00624	Nut, #6-32 Hex	2
20	2-00-00455	Flat Washer, .375 x .156 x .047	2
21	2-00-05063	Screw, #6-32 x 2.000 Lg. RHM	2
22	2-00-00518	Lock Washer, Helical Spring	2

C0485

BACK-UP ALARM - EXPLODED VIEW

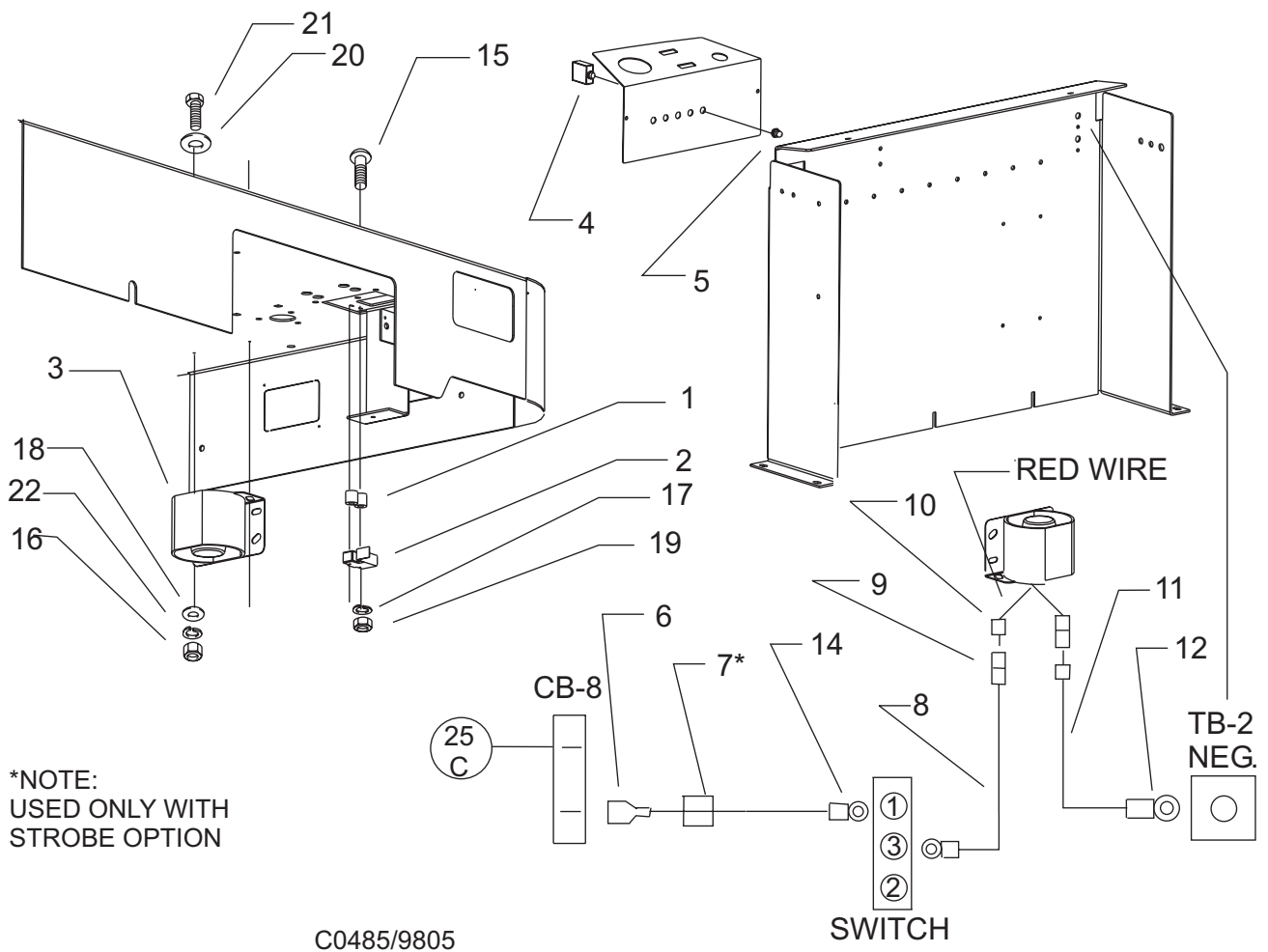

BATTERY OPTIONS

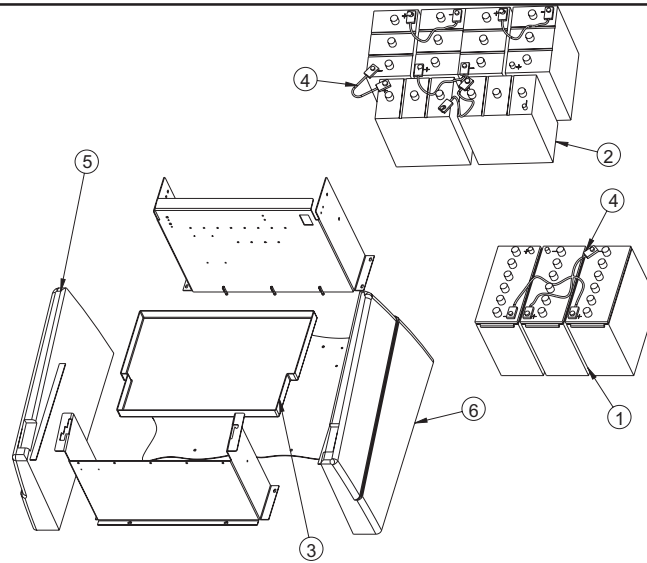

C455a/9811

<u>KEY NO.</u>	<u>PART NUMBER</u>	<u>DESCRIPTION</u>	<u>QTY</u>
1	0875-105	Battery (12 Volt)	3
1	0875-106	Battery (12 Volt Dry)	-
3	0875-102	Connector Assembly	1
4	7-90-07286	Battery Connectors	2
5	7-75-01142	Battery Spacer	1

C455a/9811

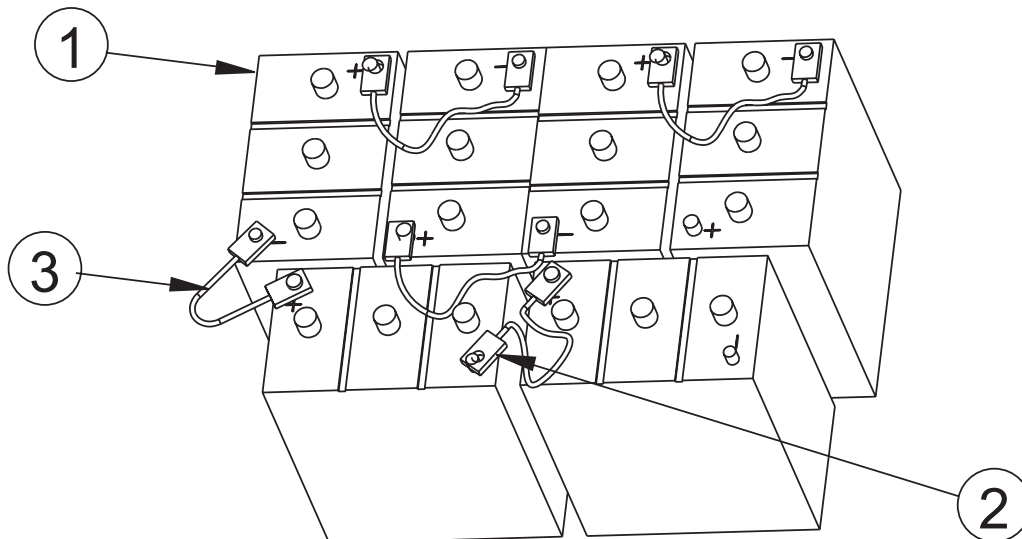

<u>KEY NO.</u>	<u>PART NUMBER</u>	<u>DESCRIPTION</u>	<u>QTY</u>
1	0875-103	Battery (6 Volt Wet)	6
1	0875-104	Battery (6Volt Dry)	-
2	0875-102	Connector Assembly	1
3	7-90-07286	Battery Connectors	5

C455c/9811

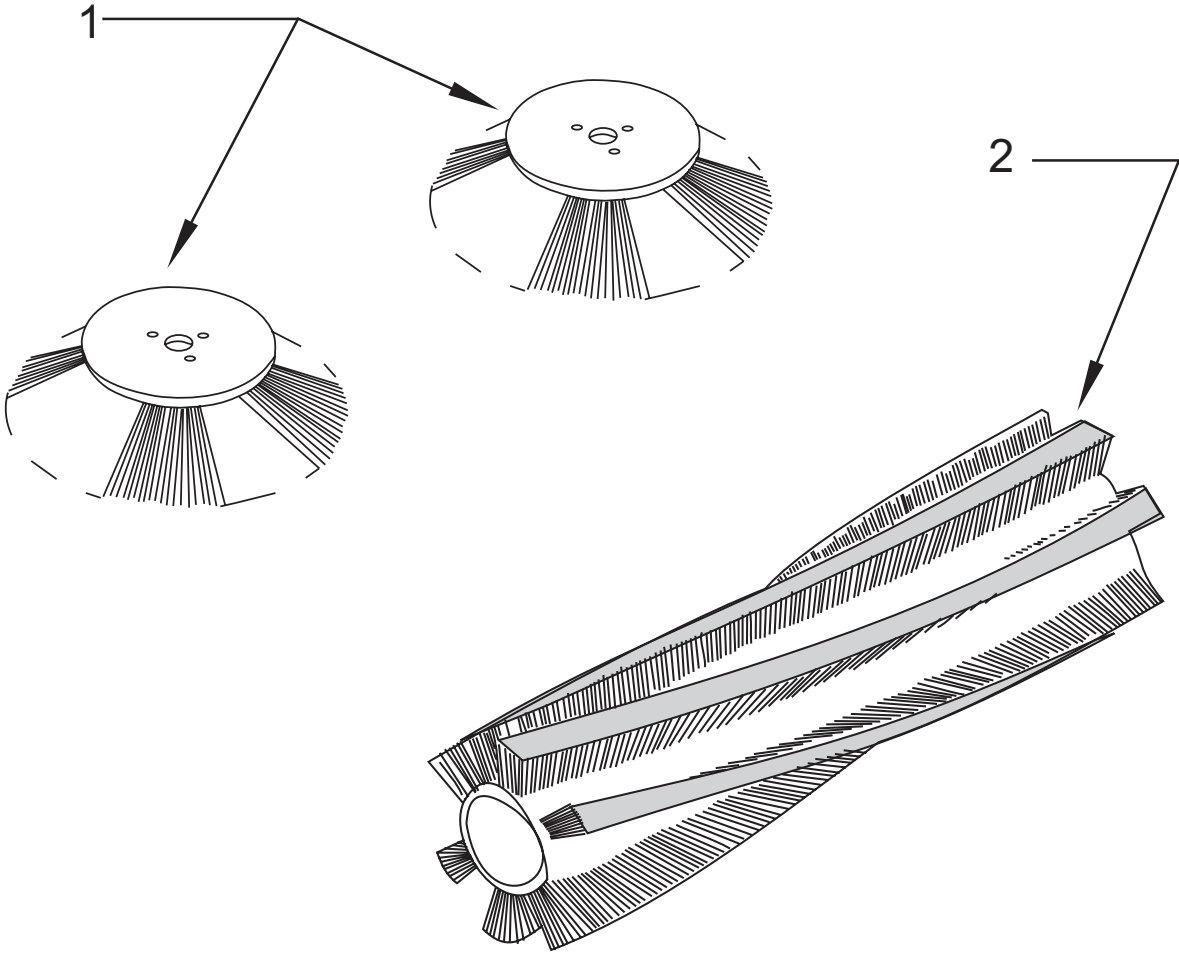

C0486

<u>KEY NO.</u>	<u>PART NUMBER</u>	<u>DESCRIPTION</u>	<u>QTY</u>
1	8-08-03215	Side Broom, Poly	2
1	8-08-03231	Side Broom, Nylon	2
2	8-08-03216	Main Broom, Proex	1
2	8-08-03222	Main Broom, Nylon	1
2	8-08-03223	Main Broom, Hi Density Nylon	1
2	8-08-03230	Main Broom, Proex and Wire	1

C0486

HEAD & TAILLIGHT OPTION

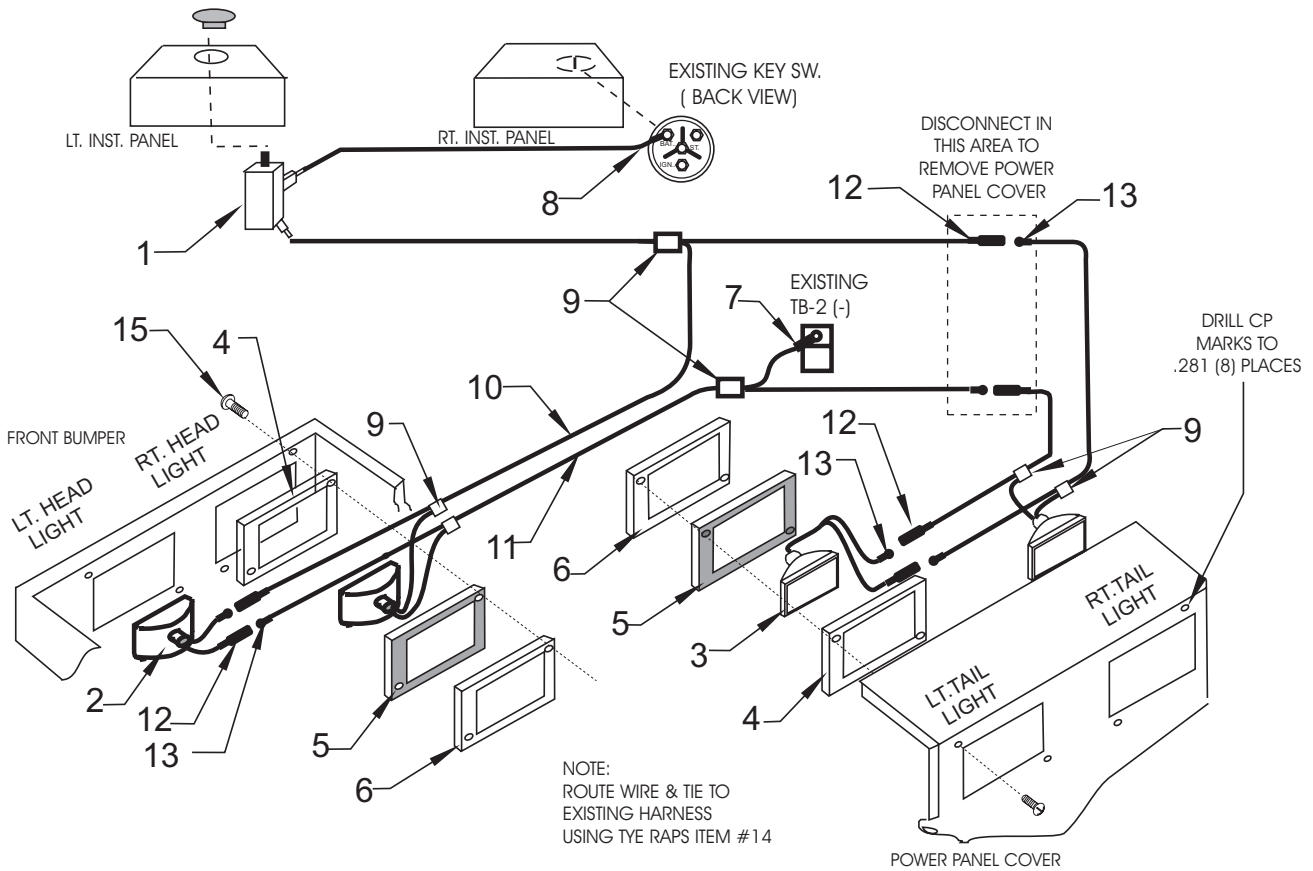

C0482

OPTION 0880-581

KEY NO.	PART NUMBER	DESCRIPTION	QTY
1	8-82-00027	Light Switch	1
2*	7-40-05031	Head Light	2
3	7-40-05032	Tail Light	2
4	7-08-00557	Bracket	4
5	7-29-00174	Bracket	4
6	7-08-00790	Bracket	4
7	2-00-04282	Terminal, Ring	1
8	2-00-04281	Terminal, #10	1
9	2-00-04479	Connector, 3-Way	6
10	3-61-00193	Wire, 16 ga. Red	15'
11	3-61-00189	Wire, 16ga. Black	15'
12	2-00-04626	Terminal, .156 Female Bullet	6
13	2-00-04578	Terminal, .156 Male Bullet	6
14	2-00-04345	Tye Raps	10
15	2-00-00203	Screw, 1/4-20 x 1.500 HHC	8

*Replacement bulb: 2-00-05338

C0482

3-6

American-Lincoln
114 RS Operator's Manual

STROBE LIGHT W/O OHG

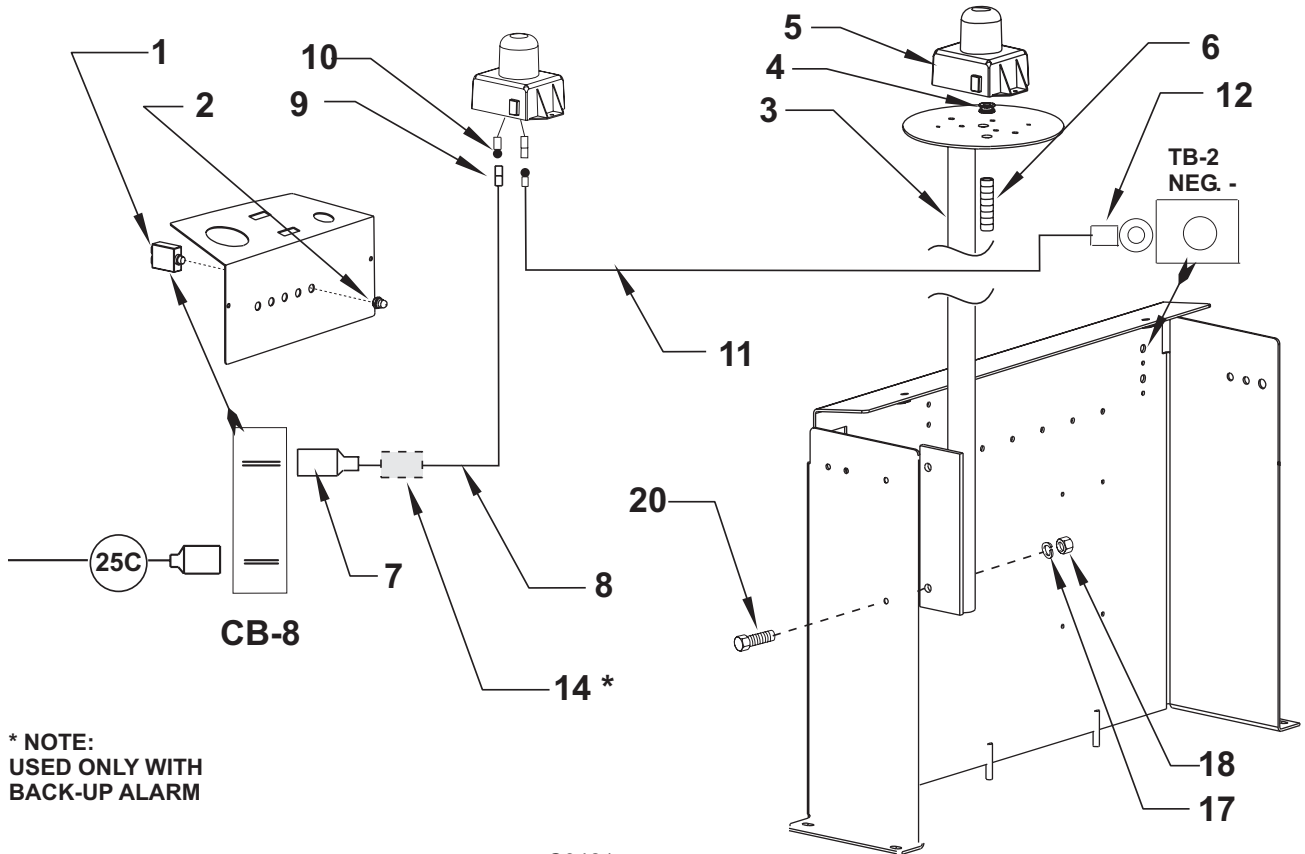

KEY NO.	PART NUMBER	DESCRIPTION	QTY
1	8-64-00007	Circuit Breaker, 10 Amp	1
2	8-11-00044	Boot	1
3	8-81-00169	Support, Warning Light	1
4	2-00-00491	Grommet	1
5	8-40-05036 8-40-05020	Strobe Light, Amber (OPTION 0880-582) Strobe Light, Red (OPTION 0880-585)	1 Ref.
6	3-61-02014	Black Loom	1'
7	2-00-03418	Connector	1
8	3-61-00193	Wire, 16 ga. Red	15'
9	2-00-04626	Terminal, Female Bullet	2
10	2-00-04578	Terminal, Male Bullet	2
11	3-61-00189	Wire, 16 ga. Black	5'
12	2-00-04282	Terminal	1
13	2-00-04345	Tye Raps	10
14	2-00-04479	Connector, 3-Way	1
15	2-00-00512	Lock Washer, # 10 INT.	
16	2-00-00605	Nut, Hex MS # 10-24 x .375 x .125	2
17	2-00-02310	Lock Washer, Helical Spring 3/8 Med.	2
18	2-00-02360	Nut, 3/8-16 Hex.	2
19	2-00-03061	Screw, #10-24 x .500 THM	2
20	2-00-00223	Screw, 1/4-20 x 1.250 HHC	2

C0481/9403

American-Lincoln
114 RS Operator's Manual

3-7

OVERHEAD GUARD OPTION

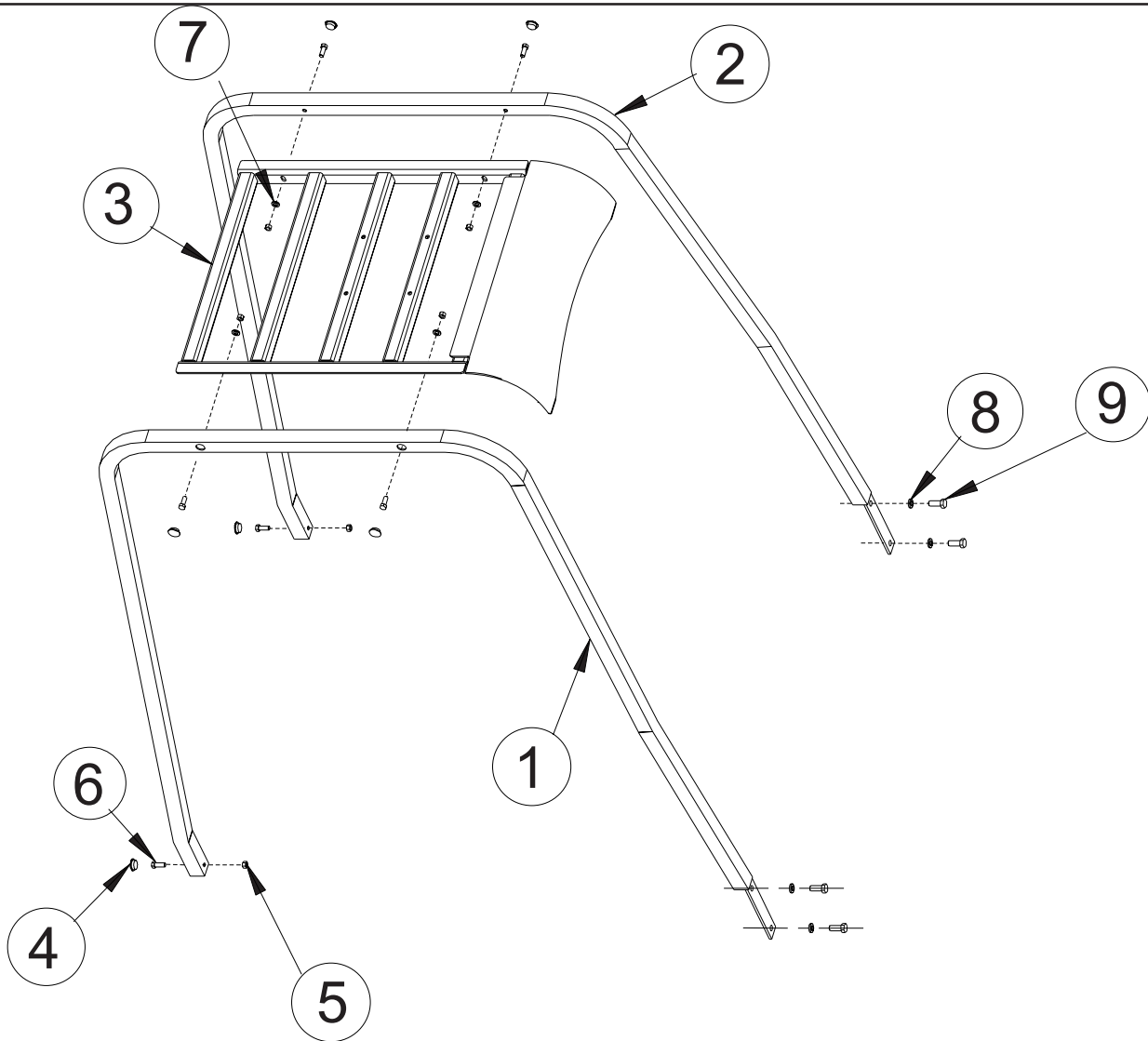

C-0560/9802

OPTION 0880-587

KEY NO.	PART NUMBER	DESCRIPTION	QTY
1	8-30-05162	Leg, L.H.	1
2	8-30-05161	Lg, R.H.	1
3	8-30-05174	Overhead Guard Top Weld	1
4	2-00-05134	Plug Button	6
5	2-95-04182	Fiber Nut	6
6	2-00-00233	Screw, 3/8-16 x 1.000 HHC	6
7	2-00-00402	Flat Washer, .750 x .390 x .094	4
8	2-00-02312	Lock Washer, 1/2 HS Med.	4
9	2-00-00240	Screw, 1/2-13 x 1.250 HHC	4

C-0560

STROBE LIGHT W/OVERHEAD GUARD

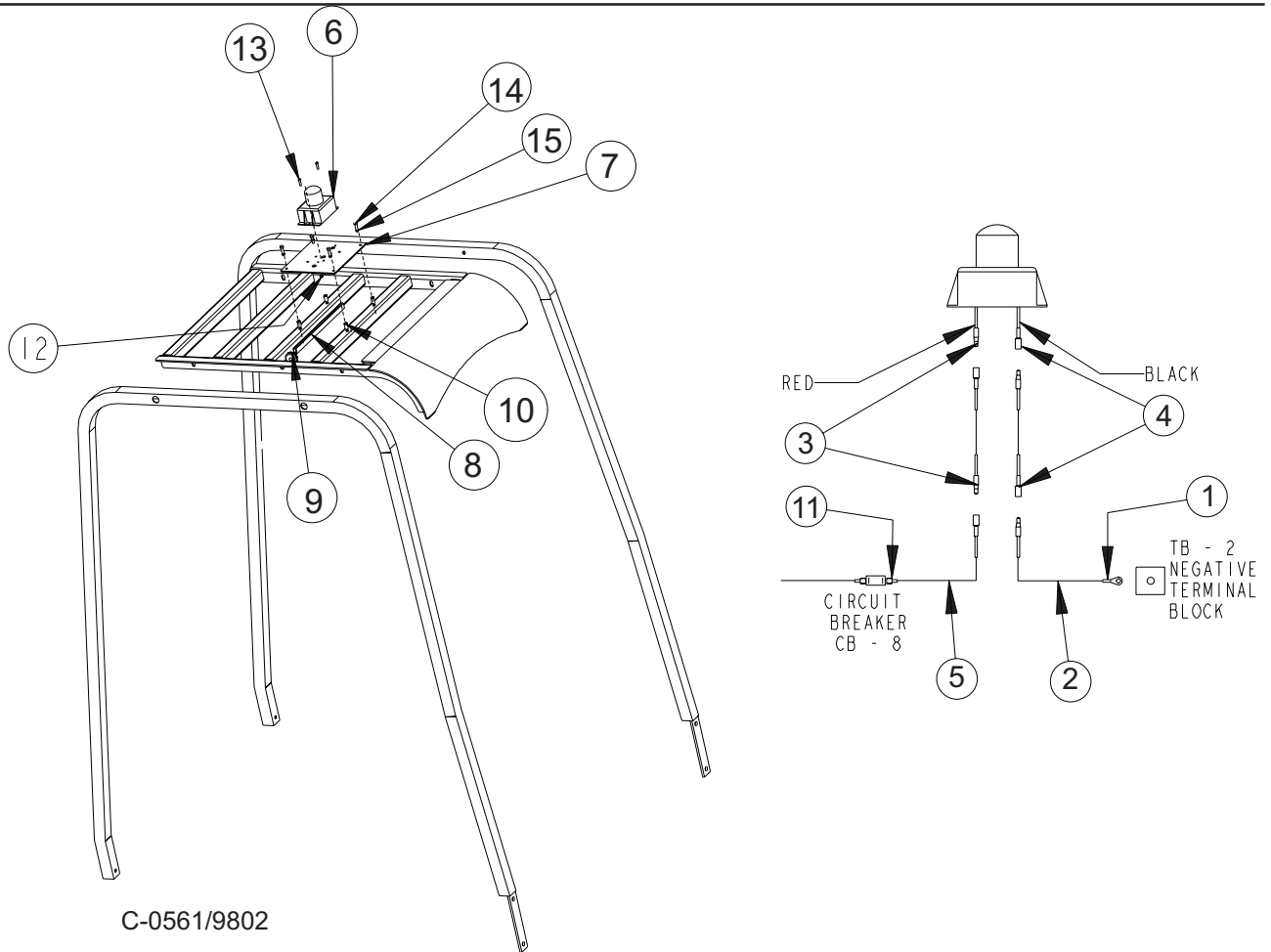

KEY NO.	PART NUMBER	DESCRIPTION	QTY
1	2-00-04282	Terminal	1
2	3-61-00189	Wire, #16 AWG. (Black)	12'
3	2-00-04578	Terminal, Male Bullet	4
4	2-00-04626	Terminal, Female Bullet	4
5	3-61-00193	Wire, #16 AWG. (Red)	12"
6	8-40-05036	Strobe Light, Amber (OPTION 0880-588)	1
	8-58-05020	Strobe Light, Red (OPTION 0880-589)	-
7	8-58-05228	Panel Light Support	1
8	8-20-06036	Duct, Wire Strip	1
9	2-00-01915	Grommet	1
10	2-00-05261	Threaded Insert	4
11	2-00-03418	Connector	1
12	2-00-01246	Nut, Hex Fiber Insert #10-24	2
13	2-00-03063	Screw, #10-24 x .750 THM	2
14	2-00-00205	Screw, 1/4-20 x 1.000 HHC	4
15	2-00-00518	Lock Washer, Helical Spring	4

C-0561

LOW BATTERY SHUTDOWN OPTION

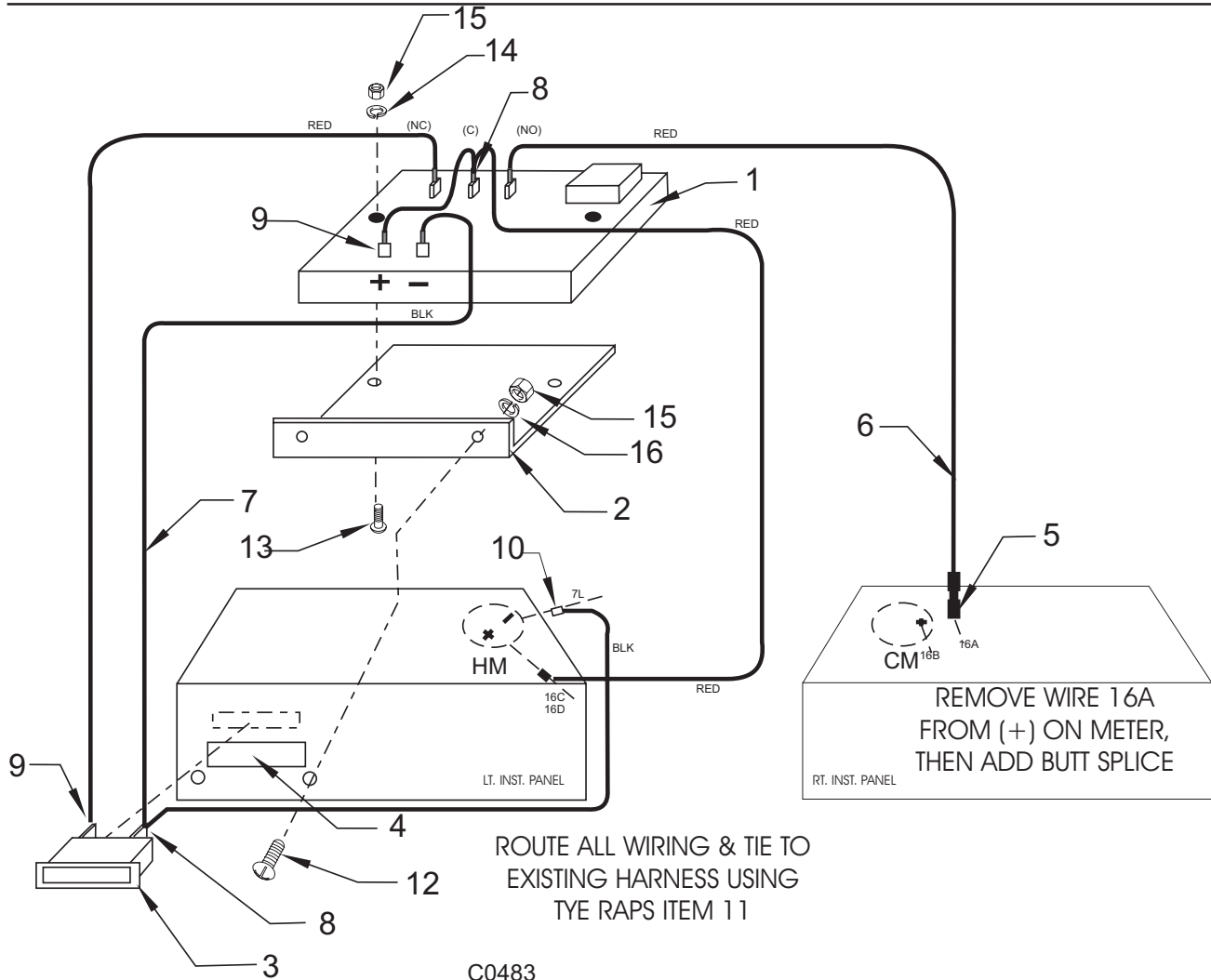

OPTION 0880-583

KEY NO.	PART NUMBER	DESCRIPTION	QTY
1	7-64-00023	Solid State Module	1
2	8-08-00748	Bracket	1
3	7-40-05030	Light, 32 volt	1
4	8-18-00390	Decal	1
5	2-00-01128	Butt Splice	1
6	3-61-00193	Wire, 16 ga. Red	15'
7	3-61-00189	Wire, 16 ga. Black	2'
8	2-00-04708	.250 FISO 10-12 ga.	2
9	2-00-03418	.250 FISO 14-16 ga.	5
10	2-00-04479	Connector, 3-Way 14 ga.	2
11	2-00-04345	Tye Raps	10
12	2-00-03059	Screw, #10-24 x .375 THM	2
13	2-00-00039	Screw, 10-24 x 1.000 RHM	2
14	2-00-00519	Lock Washer, # 10 Med HS	2
15	2-00-00605	Nut, Hex MS # 10-24 x .375 x .125	4
16	2-00-00512	Lock Washer, # 10 INT.	2

C-0483/9403

EMERGENCY STOP OPTION

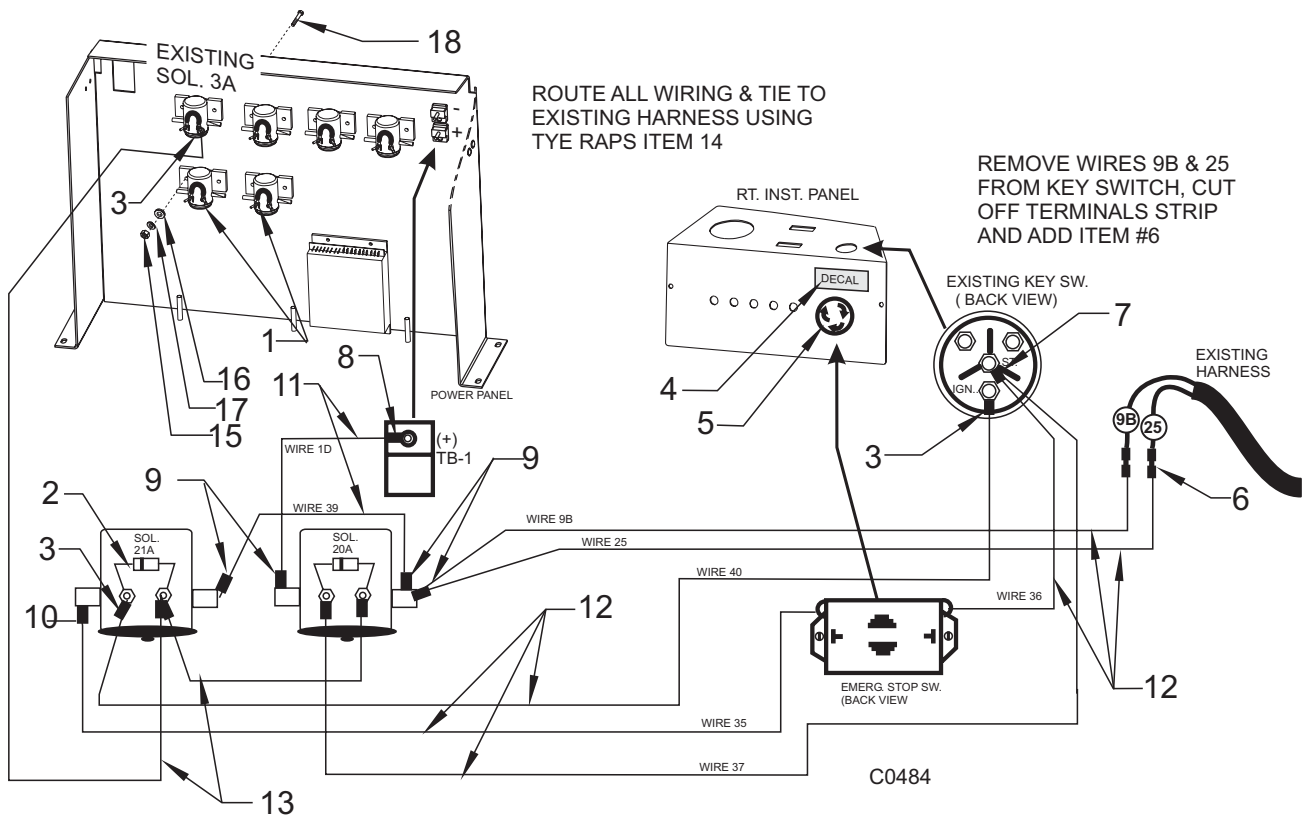

OPTION 0880-584

KEY NO.	PART NUMBER	DESCRIPTION	QTY
1	2-00-04825	Solenoid	2
2	0775-159	Diode Assembly	2
3	2-00-04719	Terminal, #10 Spring Spade	7
4	7-18-00191	Decal	1
5	7-82-00034	Emergency Stop Switch	1
6	2-00-01128	Butt Splice, 14-16 ga.	2
7	2-00-04716	Terminal, #10 Spring Spade	1
8	2-00-04859	Terminal, .250 Ring	1
9	2-00-04284	Terminal, .310 Ring	4
10	2-00-04282	Terminal, .310 Ring	1
11	3-61-00095	Wire, 12 ga. Red	3'
12	3-61-00193	Wire, 16 ga. Red	20'
13	3-61-00189	Wire, 16 ga. Black	2'
14	2-00-04345	Tye Raps	10
15	2-00-00594	Nut, Hex 1/4-20 x .437 x .218	4
16	2-00-03702	Washer, .625 x .281 x .063	4
17	2-00-00518	Lock Washer, Helical Spring	4
18	2-00-00078	Screw, 1/4-20 x .625 RHM	4

C-0484/9403

American-Lincoln
114 RS Operator's Manual

3-11

VAC WAND OPTION - PARTS LIST

OPTION 0880-621

<u>KEY NO.</u>	<u>PART NUMBER</u>	<u>DESCRIPTION</u>	<u>QTY</u>
1	8-52-00171	Panel, Vac	1
2	8-03-00053	Adapter, Hose	1
3	8-65-00047	Retainer	1
4	8-29-00242	Gasket	1
5	8-03-00054	Swivel	1
6	8-05-02022	Bag	1
7	8-31-06069	Handle	2
8			
9	7-64-00025	Circuit Breaker	1
10	2-00-03974	Toggle Switch	1
11	2-74-00059	Boot-Toggle	1
12	7-13-07097	Tab	1
13	0261-031	Carpet Tool (12")	1
14	0261-025	Wand	1
15	0261-033	Hose	1
16	8-05-01001	Baffle	1
17	0782-117	Vac Motor	1
18	7-58-05213	Plate	1
19	7-75-01128	Spacers	4
20	2-22-00003	Motor Mounting Ring	1
21	8-16-07362	Cover	1
22	8-68-05082	Seal	2
23	8-68-05083	Seal	2
24	8-23-03069	Fastener	2
25	8-23-03070	Retainer	2
26	8-23-03071	Receptacle	2
27	2-00-04859	Terminal .25 Ring	2
28	2-00-04708	Terminal .25 Female FISO	2
29	2-00-05183	Terminal .25 Male FISO	2
30	2-00-04714	Terminal #6 Spring Spade	4
31	3-61-00096	Wire #12 AWG (Black)	5'
32	2-00-04345	Tye-Wrap	5
33	7-18-00121	Decal - Warning	1
34	7-18-00227	Decal Warning	1
35	8-18-00387	Decal - American-Lincoln	1
36	8-18-00447	Decal, Caution (Wire 14)	1
37	2-00-00519	Lock Washer, # 10 Med HS	4
38	2-00-00605	Nut, Hex MS #10 - 24 x .375 x .125	8
39	2-00-00645	Nut, Hex Fiber Insert #6-32	4
40	2-00-00589	Nut, Hex Jam, .25-20	2
41	2-00-00221	Screw, 1/4-20 x .750 HHC	6
42	2-00-00107	Screw, #10-24 x 4.50 RD. HD. 4	
43	2-00-04312	Screw, #10-24 x .625 T/C Hex HD.	1
44	2-00-00044	Screw, #8 - 32 x .500	4
45	2-00-03061	Screw, #10 - 24 x .50 THM	8

C-0559/9805

VAC WAND OPTION - EXPLODED VIEW

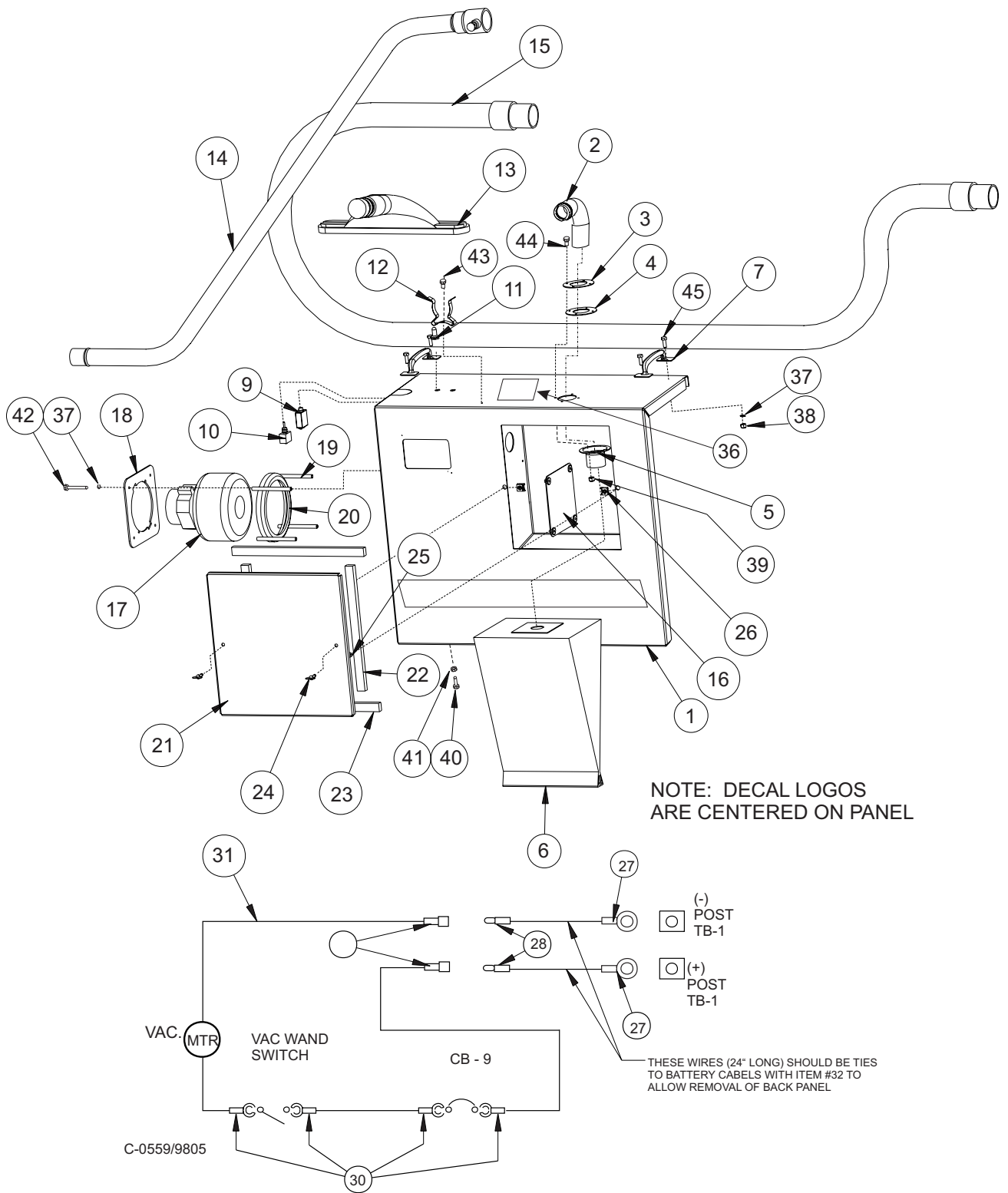

SEAT SAFETY SWITCH - PARTS LIST

OPTION 0880-669

<u>KEY NO.</u>	<u>PART NUMBER</u>	<u>DESCRIPTION</u>	<u>QTY</u>
1	0875-126	Wire Assy., Seat Switch	1
2	2-00-04531	Terminal, .25 Fisco Male	1
3	2-00-04536	Terminal, .25 Fisco Female	1
4	0882-069	Controller	1
5	2-00-00491	Grommet	1
6	8-82-00064	Seat Switch	1
7	2-00-04345	Tye-Raps	5
8	2-00-04873	Clamps	2

C0986

SEAT SAFETY SWITCH - EXPLODED VIEW

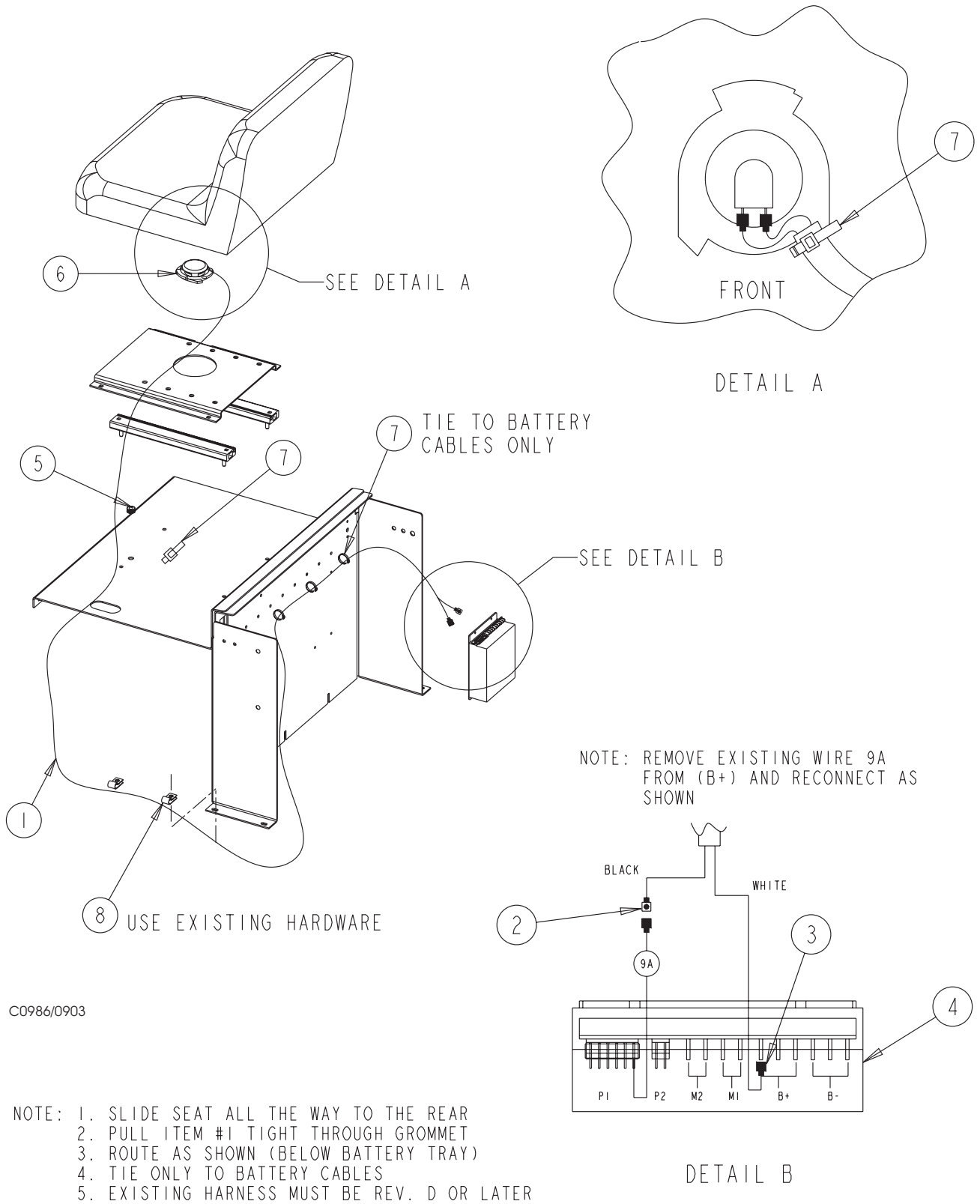

C0986/0903

DRIVE MOTOR SERVICE PARTS

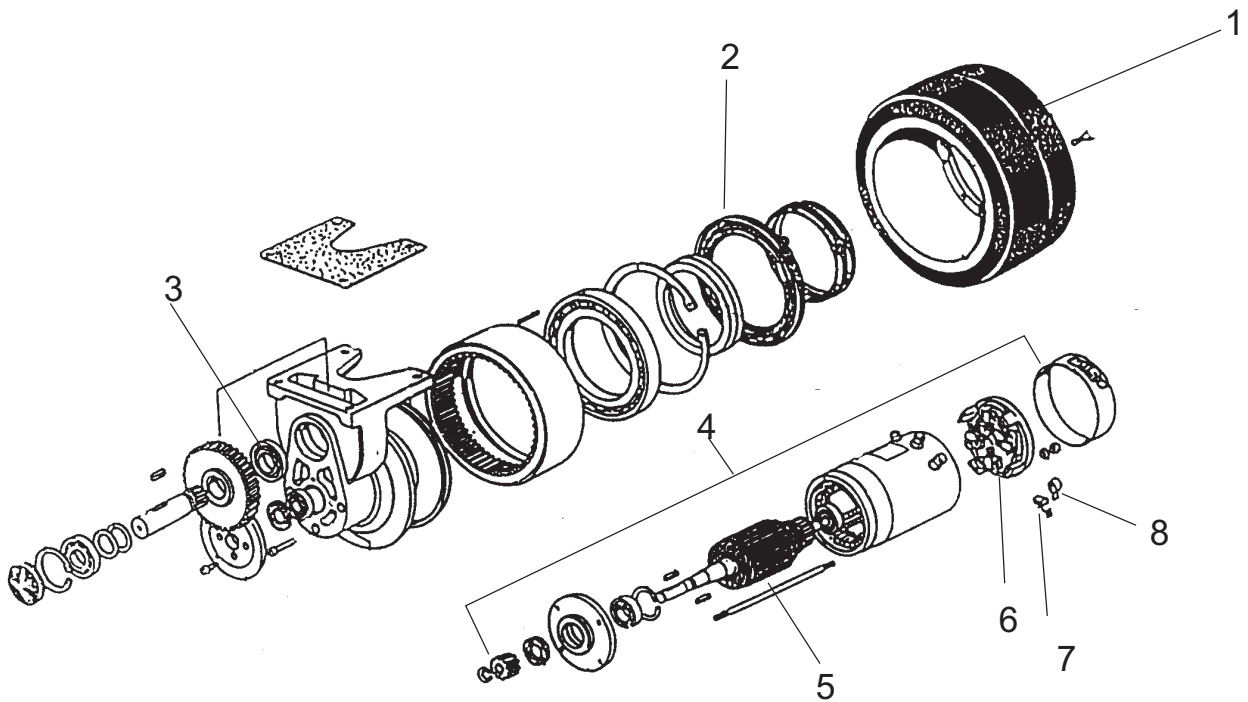

C0488/9802

<u>KEY NO.</u>	<u>PART NUMBER</u>	<u>DESCRIPTION</u>	<u>QTY</u>
1	2-60-02284	Rubber Wheel	1
2	2-60-02285	Oil Seal	1
3	2-60-02286	Bearing	1
4	2-60-02287	DC Motor, Diameter 113mm	1
5	2-60-02288	Rotor	1
6	2-60-02289	Brush Holder	1
7	2-60-02290	Brush	4
8	2-60-02291	Spring	4
9	2-60-02309	Protection Shield	1

C-0488

SPARE PARTS PACKAGE- 0880-590

KEY NO.	PART NUMBER	DESCRIPTION	QTY
1	0775-159	Diode Assembly	1
2	0875-113	Potentiometer	1
3	0860-624	Shaker Motor	1
4	2-00-02049	Bearing (Broom Drive)	1
5	2-00-03306	Bearing (Broom Drive)	1
6	2-00-04825	Solenoid	1
7	2-00-05226	Bearing (Rear Wheel)	2
8	2-00-05259	V-Belt (Broom Drive)	1
9	7-28-00001	Circuit Breaker (35 amp)	1
10	7-64-00022	Circuit Breaker (20 amp)	1
11	7-64-00025	Circuit Breaker (25 amp)	1
12	7-76-00102	Spring (Wheel Lock)	1
13	7-82-00037	Switch	1
14	8-08-03215	Side Broom	1
15	8-08-03216	Broom (Proex)	1
16	8-24-04074-1	Panel Filter	1
17	8-25-08186	Flap (Rear Inner)	1
18	8-25-08187	Flap (LH Door)	1
19	8-25-08188	Flap, (Front Outer)	1
20	8-25-08189	Flap, (Front Inner)	1
21	8-25-08190	Flap, (Rear Outer)	1
22	8-25-08191	Flap, (Right Side)	1
23	8-25-08192	Flap, (Wheel Drive)	1
24	8-29-00224	Seal, (Door Upper)	1
25	8-29-00225	Seal, (Door Lower)	1
26	8-29-00226	Seal, (Hopper Center)	1
27	8-68-05072	Seal, (Hopper Side)	1
28	8-82-00044	Switch, (Dust Control/Side Brooms)	1
29	8-82-00045	Switch, (Filter Shaker)	1

9705

INDEX

AMBER STROBE LIGHT OPTION	3-8
BACK-UP ALARM OPTION	3-2
BATTERIES, TO REMOVE THE	1-23
BATTERIES , TO CHARGE THE	1-23
BATTERY CONDITION METER	1-14
BATTERY OPTION	3-4
BATTERY SERVICE INSTRUCTIONS	1-23
BROOM OPTION	3-5
CONNECTION DIAGRAM	1-24
CONSOLE ASSEMBLY	2-12
DECALS	2-26
DECIMAL-METRIC CONVERSION TABLE	1-8
DOORS, FLAPS & SEALS	2-6
DRIVE COMPARTMENT & SEAT	2-16
DRIVE MOTOR SERVICE PARTS	3-16
DRIVE WHEEL & SIDE FLAPS, TO ADJUST THE	1-22
DUST CONTROL INSTRUCTIONS	1-21
DUST CONTROL SWITCH	1-14
EMERGENCY STOP BUTTON OPTION	1-14, 3-11
FILTER BAFFLE, TO CLEAN THE	1-21
FILTER SHAKER SWITCH	1-12
FILTER SYSTEM	2-14
FLAP INSTRUCTIONS	1-22
FOOT PEDAL	1-13
FORWARD/REVERSE PEDAL	2-10
HARDWARE ABBREVIATIONS	1-26
HEAD AND TAILLIGHT OPTION	3-6
HELPFUL HINTS FOR SWEEPING OPERATION	1-16
HOPPER	2-9
HOPPER RELEASE LATCH	1-14
HORN BUTTON	1-12
HOUR METER	1-12
INDEX	3-18
INSTRUMENT PANEL	2-24
KEY SWITCH	1-12
LIGHT SWITCH	1-12
LOW BATTERY LIGHT OPTION	1-14
LOW BATTERY SHUTDOWN OPTION	3-10
MACHINE CONTROLS	1-12
MACHINE DIMENSION	1-4
MACHINE PREPARATION	1-11
MACHINE SPECIFICATION	1-5
MAIN BROOM	2-2
MAIN BROOM INSTRUCTIONS	1-19
MAIN BROOM LIFT LEVER	1-14

MAIN BROOM SWEEP PATTERN, TO CHECK THE	1-19
MAIN BROOM, TO CHANGE THE	1-19
MAIN BROOM, TO ADJUST THE SWEEP HEIGHT	1-19
OPERATING INSTRUCTIONS	1-15
ORDERING PARTS	1-27
OVERHEAD GUARD OPTION	3-7
PANEL FILTER, TO CHANGE THE	1-21
PANEL FILTER, TO CLEAN THE	1-21
POST OPERATION CHECK LIST	1-16
POST START CHECK LIST	1-15
POWER PANEL	2-22
PRE-START CHECK LIST	1-15
RECYCLING FLAP, TO ADJUST THE	1-22
SAFETY PRECAUTIONS	1-9
SCHEMATIC DIAGRAM	1-25
SEAT ADJUSTMENT LEVER	1-12
SEAT SAFETY SWITCH OPTION	3-14
SERVICE CHART	1-17
SERVICE INSTRUCTIONS	1-19
SIDE BROOM HEIGHT ADJUSTMENT, TO CHANGE THE	1-20
SIDE BROOM INSTRUCTIONS	1-20
SIDE BROOM LIFT LEVER	1-12
SIDE BROOM SWEEP PATTERN, TO CHECK THE	1-20
SIDE BROOM SWITCH	1-14
SIDE BROOM, TO CHANGE THE	1-20
SIDE BROOMS	2-4
SIDE COVER & BATTERY PAN	2-8
SPARE PARTS	3-17
STANDARD HARDWARE & TORQUE VALUES	1-7
STARTING	1-15
STEERING & DRIVE	2-18
STROBE LIGHT OPTION FOR OVERHEAD GUARD	3-9
TABLE OF CONTENTS - CHAPTER 2	2-1
TABLE OF CONTENTS - CHAPTER 3	3-1
TO BEGIN THE CLEANING OPERATION	1-15
TO EMPTY HOPPER	1-16
TO STOP THE CLEANING OPERATION	1-16
TO TRANSPORT MACHINE	1-15
VAC WAND OPTION	3-12
WARRANTY	3-20
WHEEL LOCK	1-13, 2-20

AMERICAN-LINCOLN

RIDER "BUMPER-TO-BUMPER" LIMITED WARRANTY

I. COVERAGE

A. Subject to the terms and limitations stated herein, American-Lincoln warrants, to the original purchaser only, to repair or replace, at American Lincoln's option and upon the terms set out below, this product or any parts thereof (excluding normal maintenance items) which are defective in materials or workmanship, for a period of (2) two years or 2,000 hours of normal operation, from the date of purchase, whichever comes first, provided that the product is operated and maintained in accordance with American-Lincoln's Maintenance and Operations Instruction.

1. (a) During the first (90) ninety days from the date of purchase, American-Lincoln will provide, without charge, parts and on-site labor (including up to three (3) hours total round-trip travel time) to remedy a defective product or part.

(b) During the next (9) nine months or 1,000 hours (whichever come first) American-Lincoln will provide, without charge, parts and labor to remedy a defective product or part; however all travel time for on-site remedy and all shipping and freight charges for off-site remedy of the product or parts thereof shall be the sole responsibility of the purchaser.

(c) During the next (12) twelve months or a total of 2000 hours (whichever comes first) American Lincoln will provide, without charge, parts to remedy a defective product or part, however all labor, travel time for on-site remedy and all shipping and freight charges for off-site remedy of the product or parts thereof shall be the sole responsibility of the purchaser.

B. In addition to the terms listed above, if applicable, the following additional warranty coverage is applied.

1. (a) American-Lincoln warrants to the original purchaser only, to repair or replace, at American Lincoln's option, and upon the terms set out below, the drive line electrical components including the electric drive propulsion motor, electric wheel drive motor and electronic drive controller, and all hydraulic pumps and motors, to provide replacement parts which are defective in material or workmanship, for a period of (3) years or 3000 hours (whichever comes first) provided that the product is operated and maintained in accordance with American-Lincoln's Maintenance and Operations Instruction.

(b) American Lincoln warrants to the original purchaser only, to repair or replace, at American Lincoln's option and upon the terms set out below, the internal combustion liquid cooled engine (long block only), those parts which are found to be defective in material or workmanship for 5 years unlimited hours. American Lincoln reserves the right to have such failures evaluated by a local authorized dealer for those engines to determine warranty eligibility. All labor, travel time, shipping and freight charges shall be the sole responsibility of the purchaser. NOTE: All other parts on the engine, i.e. carburetors alternators, etc. are covered by the two year 2000 hour standard warranty.

(c) American-Lincoln, warrants to the original purchaser only, to repair or replace, at American Lincoln's option and upon the terms set out below, the main frame, debris hopper, solution and recovery tank, for the life of the machine against failure caused by defects in workmanship or total rust through. For purposes of this coverage, cosmetic deterioration or surface rust does not constitute a failure.

(d) American-Lincoln, warrants to the original purchaser only and upon terms set below, to replace batteries which become unserviceable under normal use, within a period of ninety (90) days from date of sale to the original user with new batteries of equal value. After expiration of the above ninety (90) day period, any battery which fails under normal use will be adjusted to the original user with a new battery of equal specifications on an eighteen (18) months pro rate basis from the date of purchase. Adjustment will be determined using the then current list price, plus transportation costs. Warranty is rendered null and void if battery is not kept filled to the proper level with distilled water.

II. EXCLUSIONS

A. This warranty **does not** cover normal maintenance parts and labor, including but not limited to, rubber parts, seals, flaps, brushes, engine maintenance parts, hoses, carbon motor brushes, fluids and routine adjustments.

B. This warranty **does not** cover damage or failure of the product or any parts thereof which is the result of misuse, negligent operation, handling or repair, or which is the result of modification by any person other than an authorized American-Lincoln service representative.

III. LIMITATIONS

A. AMERICAN-LINCOLN MAKES NO WARRANTIES OTHER THAN THOSE SPECIFIED HEREIN. ALL IMPLIED WARRANTIES OF MERCHANTABILITY AND OF FITNESS FOR A PARTICULAR PURPOSE ARE EXPRESSLY EXCLUDED. AMERICAN-LINCOLN LIABILITY UNDER THIS WARRANTY IS LIMITED TO REPAIR AND/OR REPLACEMENT OF PRODUCTS OR PARTS AS SET OUT HEREIN. AMERICAN-LINCOLN SHALL NOT BE LIABLE FOR ANY INCIDENTAL OR CONSEQUENTIAL DAMAGES WHICH MAY RESULT FROM A PRODUCT OR PART DEFECT OR FAILURE. ANY EXTENSIONS OF OR MODIFICATIONS MADE TO THIS WARRANTY BY A DISTRIBUTOR OF AMERICAN-LINCOLN ARE THE SOLE RESPONSIBILITY OF THE DISTRIBUTOR.

IV. Warranty eligibility terms and conditions:

1. The original purchaser shall promptly complete and return the warranty and installation registration form included with the product at the time of the purchase;
2. Upon product or part failure, the original purchaser shall promptly contact the nearest authorized American-Lincoln Servicing Representative.
3. American Lincoln reserves the rights to request that defective parts or product are returned to American Lincoln for determination of claim eligibility.

American-Lincoln Technology reserves the right to make changes and improvements to its machines without notice. For best results, use only the correct American-Lincoln Service parts.

Revised 2/03